

HEADSHOK® LEFTY OWNER'S MANUAL

Congratulations and thanks for your purchase of the HeadShok Lefty suspension system. You have invested in a suspension system that is light weight and offers maximum adjustability and absolute steering precision. This owner's manual contains important and useful information regarding the proper operation, care, and maintenance of your HeadShok fork. Please read it carefully and follow its instructions for miles of safe, high performance riding. If you have any questions about your fork or the contents of this manual, don't hesitate to contact us. See the back page for phone numbers and E-mail contacts.

The Lefty fork is a new front wheel suspension device, unlike any other fork on the market. Using an integrated axle and a single leg, the Lefty is as strong and stiff as any standard two-legged long travel fork while being lighter weight. The Lefty is available in three configurations—The Electronic Lock Out (Lefty ELO) which features push button lock out from the handlebar, the Dial Lock Out with Rebound adjustment (Lefty DLR) with on-the-fly lock out and rebound damping adjustment, and the Mechanical damper (Lefty M).

The axle spindles on the Lefty ELO and DLR are titanium for the ultimate in light weight and strength. The spindle on the Lefty M is cast stainless steel for durability and corrosion resistance.

Your HeadShok equipped Cannondale bicycle should have included both a standard owner's manual and this front suspension specific manual. If you did not receive both of these documents, please download and print one from the Cannondale website Tech Center or call our customer service line at +31 541 57 35 80 in Europe (0930 200300 from U.K.) to have one sent to you.

Please note that this manual is meant to supplement, not to replace, the Cannondale Bicycle Owner's Manual. The owner's manual contains valuable information regarding safe operation, adjustment, and maintenance of your bicycle, as well as more complete warranty information. Please read the bicycle owner's manual thoroughly before riding your bicycle, and keep it and this booklet for future reference.

REQUIRED TOOLS:

- Metric hex wrench set
- Torque wrench
- 40mm headset wrench for ELO fork assembly and battery changes (available from tool makers such as Park, Pedro's or X-Axis)

REPLACEMENT BATTERY FOR ELO FORK:

- HD300/ Ultralife lithium 9 volt battery U9VL-J or U9VL (also available from retailers such as Ace Hardware, Home Base, Radio Shack, Sears, and True Value Hardware)

FORK PRE-RIDE CHECKLIST

Before each ride, check the following items:

Stem bolts: Make sure that the stem bolts that clamp the stem to the fork are tight. Each bolt should be tightened to 77-94 In-Lbs (8.7-10.5 Nm). You can check that the stem bolts are tight enough by standing in front of your bicycle, holding the front wheel between your knees, and trying to twist the handlebars from side to side. The bars should not move.

Wheel attachment: Is your rear wheel's quick-release skewer properly fastened? Be sure to read Section 6 of the Cannondale Owner's Manual on proper operation of quick release skewers. Is the Lefty hub correctly installed and the hub bolt properly torqued to 133 In-Lbs (15 Nm)? See the section titled "Front Wheel Installation" later in this manual for proper Lefty hub installation instructions.

Brakes: Are your brakes functioning properly? With disc brakes, the brake pads must be properly installed and free from grease or oil contamination. Also, the brake pads must contact the braking surface firmly without the brake lever hitting the handlebar.

▲ WARNING: The Lefty fork must be used with a CODA or other compatible disc brake, as the disc brake acts as a secondary wheel retention device. Failure to have a properly installed disc brake rotor on the Lefty hub and a properly installed disc brake caliper on the Lefty fork could allow the front wheel to come off of the

axle spindle if the hub axle bolt is loose. A rider would be at risk of injury or death if the front wheel were to come off of the axle spindle while the bicycle was being ridden.

▲ WARNING: An approved disc brake system is very important to the safety of the Lefty fork and Cannondale strongly recommends that an authorized Cannondale dealer perform any work to the brakes. When installing disc brakes to a Lefty fork, please consult the disc brake fitting instructions that are included with the brakes. Those instructions are provided for persons who have a good knowledge of bicycle specific mechanical procedures and who are equipped with the proper tools and equipment. Incorrect installation or service may reduce braking performance, and could lead to injury or death. If you have any doubts about your ability to perform any necessary procedures, contact your local authorized Cannondale dealer.

Note that the thinner disc brake mount on the Lefty fork may require shorter caliper mounting bolts when used with a CODA Disc Brake. See your local Cannondale dealer for assistance if you need these shorter bolts.

Note also that there is a seal that is held against the disc side of the Lefty hub by the disc brake rotor. Whenever you bolt the brake rotor onto the hub, be sure that the seal rests against the large cartridge bearing and that the rotor holds the seal in place. The seal keeps out water and dirt contamination, and a missing seal will result in premature bearing wear.

▲ If you have any reason to suspect that your bicycle is not functioning properly, do not ride it. Instead, have it inspected by your authorized cannondale retailer.

FORK SETUP

Before the Lefty ELO can be used or the bike ridden, the ELO battery must be installed and the system reassembled. The ELO uses an Ultralife lithium 9 volt battery to power the motor which activates the lock out function within the Lefty. For shipping purposes, the battery and Electronic Control Unit (ECU) are packaged separately. The battery and ECU must be installed within the Lefty and the push button switch installed on the handlebar before the system will be functional. The ECU holds the battery, and houses two LEDs to indicate fork lock out (red) and low battery (yellow). Be careful not to damage the attached switch wire when handling this piece.

ELO BATTERY INSTALLATION

1. Using a 40mm headset wrench, unscrew and remove the upper collar from the top of the Lefty leg. See Fig. 1 for an illustration of the ELO components.
2. Using a 5mm hex wrench, loosen the fork upper clamp bolt. Compress the fork so that the top of the cartridge comes up through the top of the Lefty leg. This may be easiest to achieve by placing the bike upright on the floor and pushing down on the handlebars.
3. Press the new battery into the battery connection on the top of the cartridge so that the terminals mate. See Fig. 1.

Note: Do not remove the two hex head screws adjacent to the battery terminals on the cartridge outer cap for any reason. These are

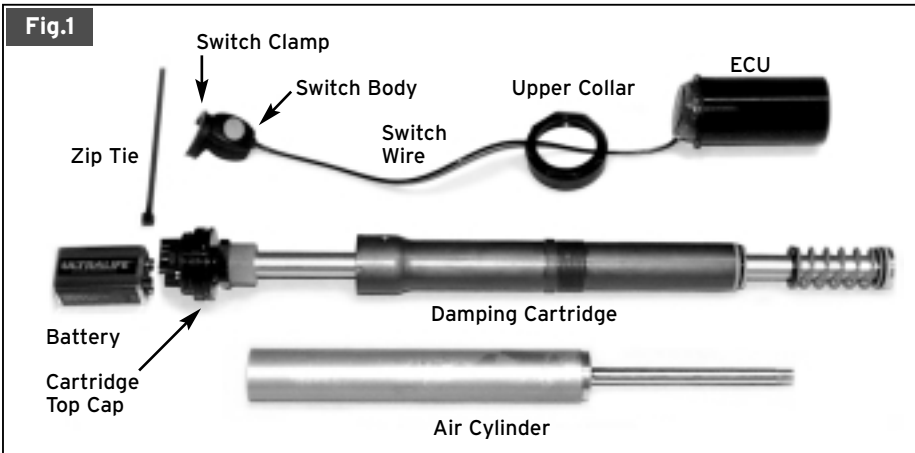

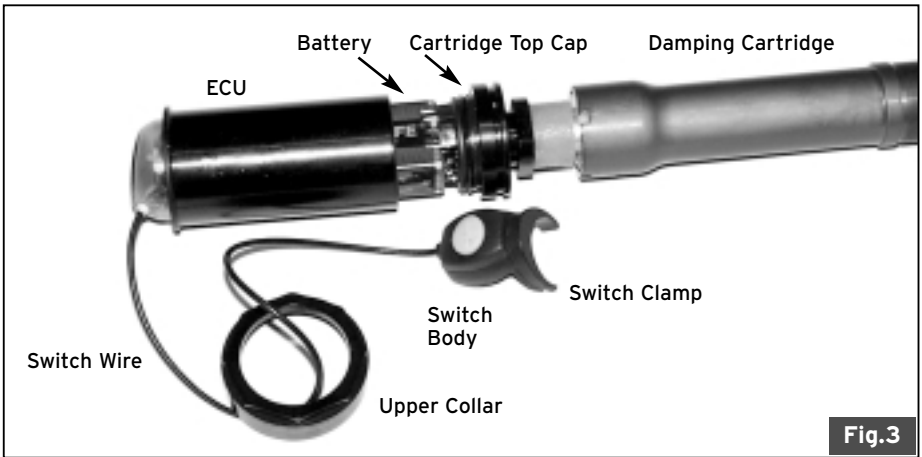
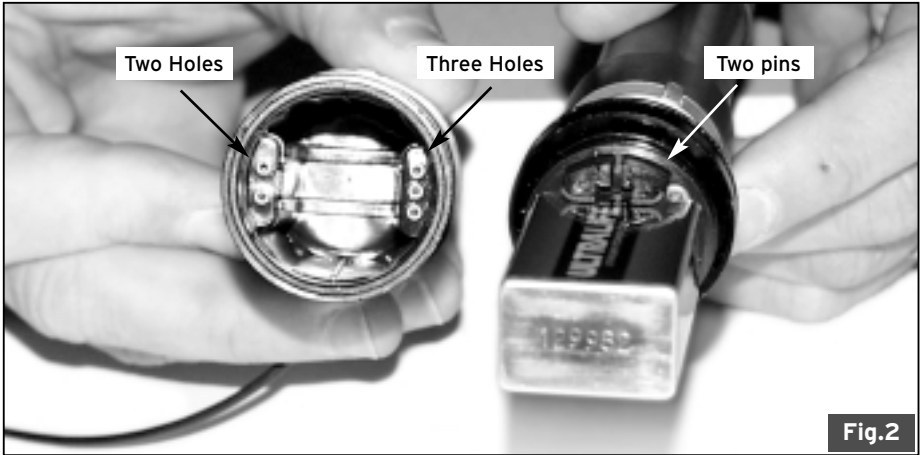

used for factory assembly of the cartridge only. Besides battery replacement, none of the ELO's electronics are user serviceable.

4. If necessary, rotate the cartridge outer cap and battery clockwise so that the three metal pins are on the right side of the battery and the two metal pins are on the left. This will assure the correct position of the Electronic Control Unit (ECU). This can best be done if the fork is still fully compressed.
5. Look at the bottom of the ECU to see that one side has three holes and the other has only two. See Fig. 2. With the fork still compressed, press the ECU into the top of the cartridge so that the sockets on the ECU and the pins on the top of the cartridge mate. See Fig. 3. The switch wire should point directly forward out of the top of the ECU.

6. Thread the switch wire through the center of upper collar, so that the threads on the collar are facing down. Using the upper collar, press down on the flange on the outside of the ECU and fully extend the fork by lifting up on the handlebars. Apply a drop of Loctite 242 (blue) to the threads on the upper collar and using the 40mm wrench, reinstall the upper collar, tightening to a torque of 250 In-Lbs (28 Nm).

7. **VERY IMPORTANT!** Apply a drop of Loctite 242 (blue) to the fork upper clamp bolt threads and tighten to 55-65 In-Lbs (6.25-7.25 Nm).

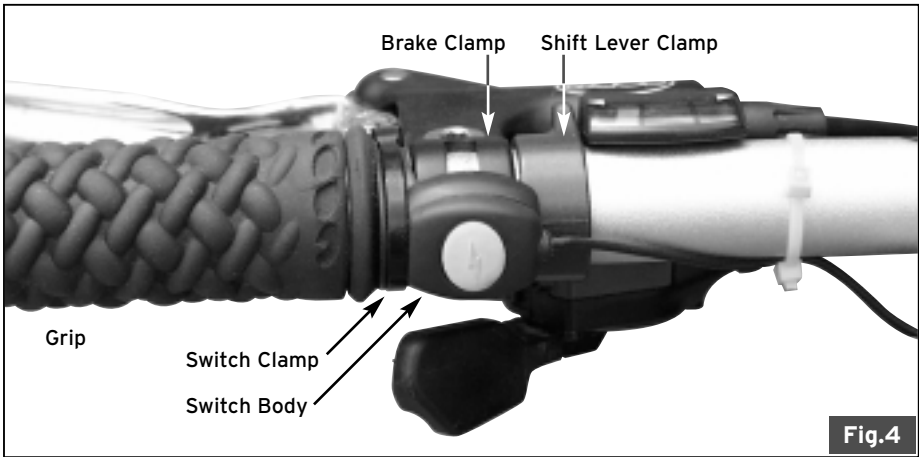

ELECTRONIC LOCK OUT SWITCH INSTALLATION

The push button switch should be placed so that the rider can easily activate the switch with their thumb. Most people find the most convenient lock out operation is achieved by placing the switch clamp on the handlebar just to the outside of the brake lever, so that the switch body sits on top of the brake lever clamp. You may have to move the brake lever to allow a 5mm space between the grip and the brake lever clamp in which to fit the switch clamp. The wire from the switch should point towards the stem, whether you mount the switch on the right or left side of the handlebar. See Fig. 4.

Some very long stems, or wide or tall handlebars may not allow for mounting of the switch on the right side of the handlebar.

Secure the switch in place with the supplied zip tie. Finish by securing any excess switch wire to the handlebar or stem using the second included zip tie. Be sure that the placement of the switch and wire will not impare steering or snag on anything while riding.

ELO BATTERY LIFE

For best performance, use only a lithium 9 volt battery such as the Ultralife U9VL-J or U9VL. An alkaline 9 volt battery can be substituted, but the battery life will be significantly shorter than that of a lithium battery. See the list of Ultralife battery retailers on the front page of this manual.

When the battery power is low, the yellow LED in the clear dome on the ECU will flash.

The battery should be replaced when the yellow low power indicator flashes.

When the yellow LED is lit continuously, battery power is too low to lock out the fork and it will return to the default active (not locked out) position. This feature will allow you to continue to ride the fork over rough terrain even if the battery is completely discharged. When the battery is dead, fork lock out is not possible. When the lock out switch is pressed, the yellow light will come on to indicate insufficient battery power. The battery must be replaced before lock out will again function.

▲ Important: For maximum battery life, store the bicycle with the Lefty ELO in the unlocked setting. When the fork is locked out, the red LED lights, using battery power. Storing the bicycle in the locked position will unnecessarily drain the battery power, shortening battery life. It is the equivalent of leaving the headlights on in your automobile.

▲ Be sure to read and heed any warnings and cautions included with the battery.

ELO BATTERY REPLACEMENT

1. Using a 40mm headset wrench, unscrew and remove the upper collar from the top of the Lefty leg. See Fig. 1 above for an illustration of the ELO components.
2. Using a 5mm hex wrench, loosen the fork upper clamp bolt. Compress the fork so that the top of the cartridge comes up through the top of the Lefty leg. This may be easiest to achieve by placing the bike upright on the floor and pushing down on the handlebars.

Pull the Electronic Control Unit (ECU) and attached switch wire off of the top of the damping cartridge. The ECU holds the battery, and houses two LEDs to indicate fork lock out (red) and low battery (yellow). Be careful not to damage the attached switch wire when handling this piece.

3. Remove the old battery from the top of the cartridge. Press the new battery into the battery connection on the top of the cartridge so that the terminals mate. See Fig. 1.

Note: Do not remove the two hex head screws adjacent to the battery terminals on the cartridge outer cap for any reason. These are used for factory assembly of the cartridge only. Besides battery replacement, none of the ELO's electronics are user serviceable.

4. If necessary, rotate the cartridge outer cap and battery so that the three metal pins are on the right side of the battery and the two metal pins are on the left. This will assure the correct position of the electronic control unit (ECU). This can best be done if the fork is still fully compressed.

5. Look at the bottom of the ECU to see that one side has three holes and the other has only two. See Fig. 2. With the fork still compressed, press the ECU into the top of the cartridge so that the sockets on the ECU and the pins on the top of the cartridge mate. See Fig. 3. The switch wire should point directly forward out of the top of the ECU.

6. Using the upper collar, press down on the flange on the outside of the ECU and fully extend the fork by lifting up on the handlebars. Using the 40mm wrench, reinstall the upper collar with a drop of Loctite 242 (blue) on the threads and torque to 250 In-Lbs (28 Nm).

7. **VERY IMPORTANT!** Apply a drop of Loctite 242 (blue) to the fork upper clamp bolt threads and tighten to 55-65 In-Lbs (6.25-7.25 Nm).

LEFTY CABLE ROUTING

The front brake line should not go through the fork clamps, but rather to the outside of the Lefty leg and behind the disc brake. See Fig. 5. Note that the zip tie loops need to be loose enough to allow the brake line to slide freely up and down.

The rear brake line and rear derailleurs cable should be run between the upper and lower

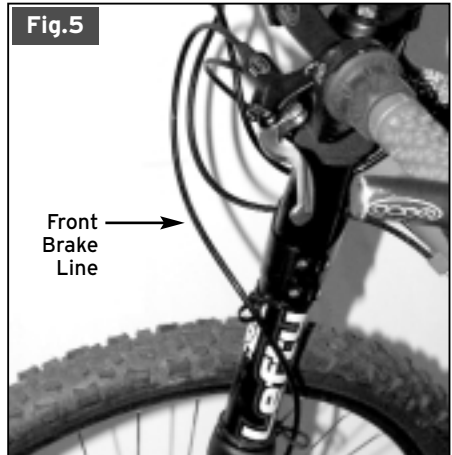

fork clamps, between the bike's head tube and the Lefty leg.

SPRING PRELOAD ADJUSTMENT FOR ALL LEFTY FORKS

Before the bike is ridden, the spring preload must be adjusted to suit the weight of the rider. If too much preload is applied, the suspension will be stiff and unresponsive; too little preload and the rider may feel "bouncing" while climbing or sprinting, and may tend to bottom out the shock (compress it to the limit of its travel) on large bumps. The HeadShok Lefty ELO and DLR use an air spring while the Lefty M fork uses the Advanced Spring System's coil spring and MicroCellular Urethane (MCU) combination. The following procedures are for initial setup only. We encourage riders to experiment with different preloads to achieve their optimal setting.

▲ Caution: The upper collar with 40mm wrench flats on the top of the Lefty DLR and Lefty M is not for any kind of adjustment, it is to allow the removal and service of the fork's internals and removal of the leg from the top crown. It should not be necessary to loosen or remove this upper collar. On the Lefty ELO, this upper collar should be removed only to change the battery in the electronic control unit. If the upper collar is loosened or removed, it should be reinstalled with a drop of Loctite 242 (blue) on the threads and torqued to 250 In-Lbs (28 Nm).

ELO AND DLR AIR SPRING PRELOAD ADJUSTMENT

Air preload adjustment requires a precision suspension air pump with gauge that is capable of delivering at least 150 psi through a Schrader valve. A check valve, quick-disconnect, or valve extension may also be helpful in preventing air loss from the valve as the pump is removed. The maximum preload pressure for the air cartridge is 225 psi.

1. With the rider off of the bike, measure from the floor to the center of one end of the handlebar with the bicycle standing perfectly upright. Then position the rider on the bike in a seated, natural riding position with both feet on the pedals and weight on the seat. It may be easiest for the rider to lean against a wall or post. With only the rear brake applied and the fork unlocked, again measure the distance from the floor to the center of the end of the handlebar.

2. The difference in these two measurements is the preload sag. Most riders find the best Lefty suspension performance with 1/2 - 5/8" (12.5-16mm) sag. A good starting point is to fill the air spring to 75% of the rider's body weight. Add or remove air from the fork through the Schrader valve located at the bottom of the Lefty leg until the desired sag measurement and fork feel are achieved. Note this air pressure setting for future reference.

LEFTY M COIL SPRING / MCU PRELOAD ADJUSTMENT

There are three different weights of coils available for the Lefty M, to allow the fork to be customized to suit riders of different weights

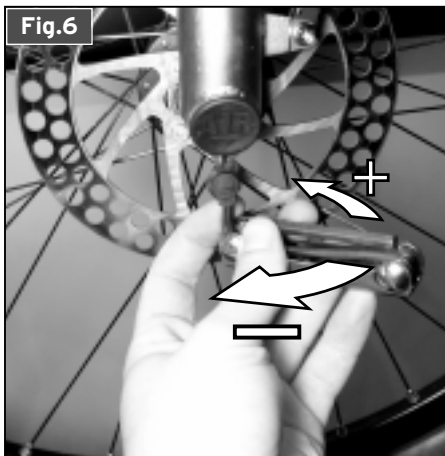

and riding styles. Note that different bike sizes come stock with different spring weights, to best suit riders of different sizes. Each spring kit also includes performance matched negative spring in the same color. The negative spring acts to increase the initial plushness of the fork by overcoming the resistance of the main spring. It also acts as a top-out spring, to prevent a harsh stop at the full extension of the fork.

Rider Weight Range	Recommended Spring	Spring Kit Code
150 lbs. or less	Green	HD219/GRE
140 - 200 lbs.	Blue	HD219/BLU
180 lbs. or more	Red	HD219/RED

Bike Size	Comes With This Spring
Small	Green
Medium	Blue
Large	Blue
Extra Large	Red
Jumbo	Red

Beyond changing the coil springs in the fork, the spring preload can be fine-tuned to suit rider weight and riding style.

1. With the rider off of the bike, measure from the floor to the center of one end of the handlebar with the bicycle standing perfectly upright. Then position the rider on the bike in a seated, natural riding position with both feet on the pedals and weight on the seat. It may be easiest for the rider to lean against a wall or post. With only the rear brake applied, again measure the distance from the floor to the center of one end of the handlebar.

2. The difference in these two measurements is the preload sag. Most riders find the best suspension performance with 1/2 - 5/8" (12.5 - 16mm) preload sag compression. To change the amount of sag, pull the rubber cap out of the bottom of the Lefty fork leg and insert 5mm hex wrench into the hole in the bottom of the leg. Turn the preload adjustment screw clockwise for greater preload (less sag compression) or counter-clockwise for less preload (more sag compression). See Fig. 6. Note that for full suspension use Cannondale recommends running the Lefty M in the soft end of the adjustment range to allow more shock sag.

3. When desired preload is set, replace the rubber cap.

LEFTY NEGATIVE SPRINGS

Lefty forks come with three different weight negative springs and degrees of rebound damping, for riders of different weights and riding styles. The coil negative spring should not be confused with the main spring, which acts to set the stiffness of the fork. The negative spring acts to control the initial plushness of the fork by overcoming the resistance of the main spring. It also acts as a top out spring, to prevent a harsh stop at the rebound of the suspension travel. Heavier riders or those using more preload in the main spring (for a stiffer ride) will want a heavier negative spring and more rebound damping. See the following chart for negative spring information. Your local dealer can advise you about changing springs.

Bike Size	Comes With This Spring	Kit Code
Small	Green	HD212/GRN
Medium	Blue	HD212/BLU
Large	Blue	HD212/BLU
Extra Large	Red	HD212/RED
Jumbo	Red	HD212/RED

FRONT WHEEL REMOVAL

The Lefty front hub uses a self-extracting bolt to attach the wheel to the Lefty's axle spindle. The bolt is held into the hub by a cap that is screwed into the non-disc side of the hub using a pin spanner tool. The self-extracting bolt and cap combination is very similar to that used on CODA Tarantula Competition or Shimano XTR, Dura Ace, and Ultegra cranks, except that the Lefty hub cap has left hand

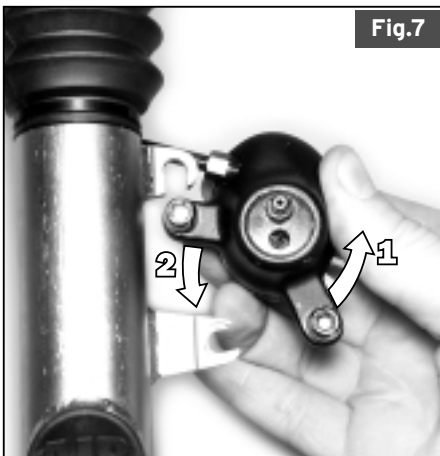

Fig.7

threads. The cap should not be removed; it is there to hold the axle bolt into the hub. If you do need to remove the cap to replace the bolt, be sure to reinstall the cap with a drop of Loctite 242 (blue) on the cap threads. Remember that the cap will need to be turned counter-clockwise to be screwed in.

NOTE: It is not necessary to remove the front wheel from the Lefty fork to change an inner tube or tire. Simply remove the tire from the wheel as you normally would using a tire lever, making sure to pull the tire off of the non-disc side of the wheel.

1. Using a 5mm hex wrench, loosen (but don't remove) both front disc brake caliper bolts. Pivot the bottom of the brake caliper counter-clockwise so that the bottom caliper bolt swings out the back of the Lefty's disc brake mount. Then drop the top bolt down out of the disc brake mount. See Fig. 6. The wheel cannot be removed without first removing the brake from the fork.

2. Using a 5mm hex wrench, unscrew the axle bolt that attaches the wheel to the fork's axle spindle in a counter-clockwise direction. Note that the bolt is held in the hub by the self-extracting cap, and will stay attached to the hub even when the wheel is removed from the axle spindle. There is no need to remove the cap from the hub.

3. Pull the wheel off of the axle spindle.

▲ CAUTION: Take care not to drop the fork's axle spindle on the ground when the wheel is removed. If the spindle is dented, the axle bolt may not engage the axle spindle and the fork will not be usable.

FRONT WHEEL INSTALLATION

1. Make sure that the CODA front disc brake is not attached to the Lefty disc brake mount. It is not possible to install the wheel with the brake installed on the fork. If necessary, remove the front disc brake caliper from the fork using a 5mm hex wrench as instructed in step 1 of the FRONT WHEEL REMOVAL section above.

2. Apply a light coat of good quality bicycle grease to the flat bearing seats on the tapered axle spindle of the fork. Also smear a little grease on the axle bolt threads inside the end of the axle spindle. Take care not to get any grease on the disc brake or brake rotor attached to the hub.

Note: It is very important that you grease the axle bolt threads inside the end of the axle spindle, especially on the titanium spindles found on Lefty ELO and DLR forks. If over-tightened, an unlubricated bolt threaded into a titanium structure will seize, making removal difficult or impossible without damaging the bolt or spindle.

3. Slide the front wheel onto the axle spindle with the disc side of the hub closest to the fork leg. Make sure to press the wheel straight onto the axle spindle so that the bolt threads will correctly engage with the threads in the spindle. Using a 5mm hex wrench, tighten the axle bolt to 133 In-Lbs (15 Nm). See Fig. 8. It is sometimes easiest to install the front wheel by laying the bike down on the left side, axle spindle facing up. Then place the hub straight down on the spindle, and tighten the axle bolt.

Fig.8

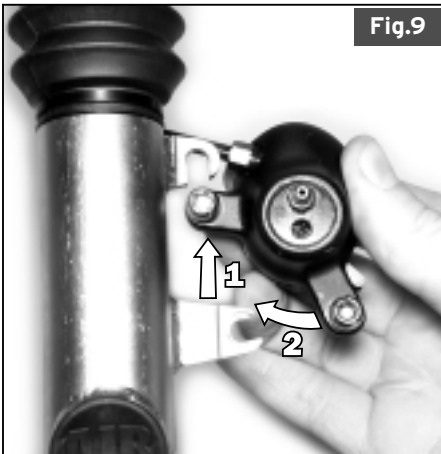
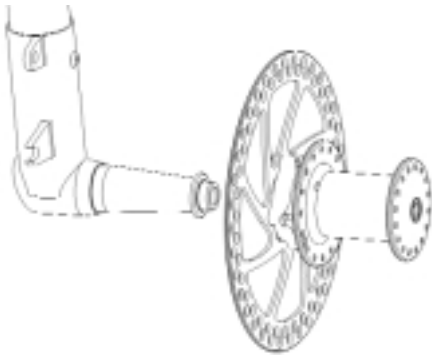

Fig.9

4. Reinstall the brake caliper to the Lefty's disc brake mount. You will need to first slip the caliper over the brake rotor so that rotor runs between the brake pads. Check to be sure that both brake pads are in the caliper. Then slide the top caliper bolt up into the disc brake mount, and rotate the bottom of the caliper clockwise into the bottom caliper bolt slot. See Fig. 9. Be sure that the spacing shims are on the inside of disc brake mount (against the brake caliper body), not directly under the head of the caliper bolts. Using a 5mm hex wrench, tighten both brake caliper bolts to 69-78 In-Lbs (8-9 Nm).

LOCK OUT FUNCTION (LEFTY DLR AND ELO ONLY)

Both the Lefty ELO and DLR feature on-the-fly lock out allowing the rider to turn the shock absorber on or off as desired. The ELO lock out is activated by pushing the button attached to the handlebar and connected to the Lefty cartridge by the switch wire. The Lefty DLR lock out is activated by turning the black lock out knob located atop the Lefty leg clockwise to lock out the suspension action of the fork, or counter-clockwise to activate the suspension.

ON-THE-FLY DAMPING ADJUSTMENT (LEFTY DLR ONLY)

Lefty DLR cartridges allow "on-the-fly" adjustment of the low speed (small bump) damping by means of the red damping dial located in the center of the larger black lock out knob. Turning the small red dial all the way counter-clockwise adjusts the damping to its most open, compliant setting (minimum damping.) Conversely, turning the dial clockwise will increase the damping. The red slow speed damping dial is only for adjustment, it does not lock out the suspension action (the larger lock out knob controls the lock out.)

HEAD TUBE ANGLE ADJUSTMENT

The Lefty fork is designed to be set up so that the upper collar on the top of the fork leg is flush with the top of the upper clamp. However, it is possible to slightly decrease the height of the front of the bike while simultaneously increasing the head tube angle of the bike. Note that a steeper head tube angle will change the steering and handling of the bike.

1. Loosen the clamp bolts and slide the leg up in the clamps until the lower clamp is 110mm

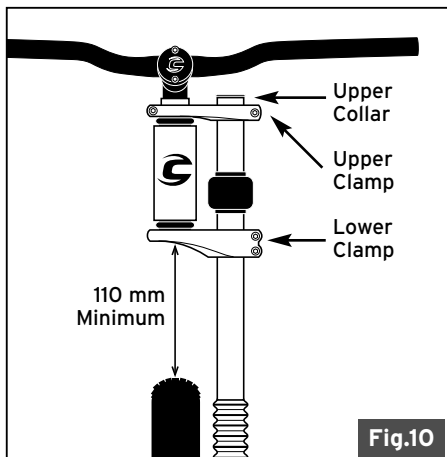

from the tire (see Fig. 10). Mark the fork leg at this point with a marker or tape. This is the lowest safe adjustment for the fork clamps. Do not scribe or scratch the fork leg with an awl, file, or similarly sharp object.

▲ Caution: This lowest safe adjustment point will change if you change the front tire. If you change to a larger front tire, you must again check that you have at least 110mm of clearance between the bottom of the lower crown and the tire before riding the bike.

2. Adjust the fork leg in the clamps within the range defined by the upper collar on the top of the leg and the mark which you made indicating the lowest safe position for the clamps.

▲ WARNING: If the Lefty fork clamps are set with less than 110mm of clearance between the tire and the bottom of the lower clamp, there is a risk of contact between the tire and the lower clamp when the fork is completely compressed. If such tire / clamp contact occurs while riding, the front wheel could stop suddenly and throw the rider over the handlebars, with risk of serious injury or death.

3. Apply grease to the threads of all four clamp bolts and using a 5mm hex wrench tighten the bolts to 55-65 In-Lbs (6.25-7.25 Nm).

HEADSHOK SCHEDULED MAINTENANCE

It is recommended that you take your Lefty fork to your Authorized HeadShok Service Center for a regular tune up every two months or 40 hours of riding. Your fork is a high performance suspension system and needs regular inspection, lubrication, and maintenance.

Your mechanic will check the following items and service the fork as necessary. Between these tune-ups, you will also want to occasionally check your HeadShok as outlined below.

FRAME AND FORK

Once a month, or every few rides, clean and inspect the entire frame and fork for any dents, cracks, or other damage. If any damage to the frame or fork is found, do not ride the bicycle. Have the damage inspected and assessed by a Cannondale or HeadShok dealer.

HEADSET BEARING SEAL

All Lefty forks and all other forks which come with the new lightweight HeadShok stem (which can be identified by its two clamp bolts) use a secondary black rubber seal on top of the top headset bearing. For the Lefty fork this seal goes below the top clamp, against the headset bearing. Single crown forks use the seal below the stem, against the bearing. This seal will keep water and dirt out of the headset bearing.

SUSPENSION FORK BOOT

Frequently inspect the rubber boot at the base of the leg of the Lefty fork for tears, cuts, or broken zip ties that could allow contamination. The fork boot protects the needle bearings and bearing races from water, dirt, and other contaminants. Make sure that the brake tubing has not rubbed a hole in the boot. If the tubing is rubbing on the boot, you should re-route it to eliminate the contact. Your local Cannondale retailer can help you with this procedure.

If the boot is damaged in any way, it must be replaced immediately. On the Lefty fork, it is necessary to remove the front brake, loosen the leg clamps using a 5mm hex wrench, remove the upper collar from the top of the Lefty leg (using a 40mm headset wrench), drop the fork leg out of the clamps, and replace the boot. To reinstall the leg, see the "Head Tube Angle Adjustment" section of the instructions below. Your local Cannondale dealer can help you with these procedures. Damage to the HeadShok due to contamination by water or dirt will not be covered under warranty.

▲ Caution: The upper collar with 40mm wrench flats on the top of the Lefty DLR and Lefty M is not for any kind of adjustment, it is to allow the

removal and service of the fork's internals and removal of the leg from the top crown. It should not be necessary to loosen or remove this upper collar. On the Lefty ELO, this upper collar should be removed only to change the battery in the electronic control unit. If the upper collar is loosened or removed, it should be reinstalled with a drop of Loctite 242 (blue) on the threads and torqued to 250 In-Lbs (28 Nm).

INNER STANCHION TUBE

Several times a year, or if the suspension boot has been damaged, or if the fork has taken a large or unexpected impact, you should inspect the inner stanchion tube beneath the boot. Before proceeding, make sure that you have two replacement zip ties to reattach the HeadShok boot. These should be available from your local Cannondale or HeadShok Authorized Retailer. Cut both old zip ties off of the boot and pull the boot up off of the lower boot mount and down off of the lower collar. Clean this area inside the boot of any dirt and old grease. Inspect the inner races and the stanchion tube for corrosion, cracks, or a bent leg.

If there are any cracks on the telescoping assembly or if it is bent at all, the fork must be replaced immediately. DO NOT CONTINUE TO RIDE THE FORK! See your local Cannondale or HeadShok dealer.

If rust, pitting, or corrosion is present on the inner leg, you should take the fork to your Cannondale Authorized Retailer for inspection. They will assess the condition of the fork and evaluate the amount of structural damage that may have resulted.

▲ WARNING: Serious, structural corrosion on the telescoping assembly of a HeadShok fork will decrease the useful life of the fork. Corrosion or cracks on the stanchion tube, or a bent stanchion tube, may lead to the failure of the fork, which could cause an accident with attendant risk of injury or death to the rider. HeadShok forks that show signs of such structural damage in the telescoping assembly must be replaced immediately.

After completing the inspection of the HeadShok steerer tube assembly lightly coat the exposed length of the inner steerer tube and bearing races with a good quality light bicycle grease, such as Royal Purple grease, Finish Line White Teflon grease, or Slick 50 One Grease. Replace the boot onto the lower collar of the HeadShok telescoping assembly and to the bottom of the inner fork tube.

Reattach the boot with two zip ties. Make sure that the zip ties are secured tightly.

NEEDLE BEARING LUBRICATION

The needle bearings (which provide the smooth travel of the HeadShok suspension system) inside all mountain HeadShok forks should be lubricated every two months or 40 hours of riding. This procedure requires partial disassembly of the suspension fork, and therefore must be performed only by an experienced bicycle mechanic at an Authorized HeadShok Service Center.

CARTRIDGE SERVICE AND CUSTOM TUNING

The HeadShok system is incredibly versatile and can be easily adjusted or upgraded. Depending upon the model of fork, HeadShok Service Centers can advise you about changing spring preload, spring rate, compression damping, rebound damping, and on-the-fly lock out. See your dealer for more information regarding the fine-tuning or upgrading of your HeadShok Lefty fork.

Like other HeadShok damping cartridges, the Lefty ELO and DLR cartridges can be removed, serviced, adjusted, bled, and reinstalled. The ELO and DLR cartridges come stock with 5 weight oil. This can be changed to a lighter or heavier fluid for decreased or increased fork damping. Additionally, the damping characteristics can be modified by changing the internal valve shims on the oil piston. The shims on top of the piston control compression damping, while the shims under the piston control the rebound damping. Thicker shims provide more damping. These service procedures should only be performed by an experienced bicycle mechanic at an Authorized HeadShok Service Center.

WASHING THE ELO

A note on the washing of a Lefty ELO fork: Because of its electronic components, some care must be taken when washing an ELO equipped bicycle. The electronic control unit is sealed to resist penetration of water and mud when riding, but is not water proof. The ELO unit should not be totally submerged in water, nor should a high pressure water spray be directed at the unit. The best way to thoroughly wash the Lefty ELO is to use a damp sponge or rag and a little detergent if necessary.

WARNINGS

If the suspension fork ever begins to make “knocking” or “clunking” noises, or if it ever shows an unexplained increase in travel, or looks like it is extended farther than it was originally, or if the fork loses its ability to lock out (“D”, “DD”, “DL”, “DLR”, and “ELO” type cartridges only), stop riding the bike and bring it to a HeadShok dealer for inspection. Possible indications of a problem are:

- An increase in the fork’s extension or travel.
- A stretched-out fork boot.
- A stretched or strained front brake cable.
- “Knocking” or “clunking” noises coming from fork.
- A sudden loss of lock out ability on cartridges which feature lock out.

If any of the above symptoms are ignored, the result could be a separation of the fork from the bicycle frame. Separation of the fork could lead to an accident, with risk of serious injury or death.

If your bike has suspension, the increased speed you may develop also increases your risk. When braking, the front of a suspended bike dips. You could have a bad accident if your skill is not up to handling this system. Get to know how to handle your suspension system well before trying any downhill or very fast biking.

Likewise, suspension will increase handling capabilities and comfort of your bicycle. This enhanced capability may allow you to ride faster. But do not confuse the enhanced capabilities of a suspension bike with your own capabilities. Increasing your skill will take time and practice. Proceed carefully until you are sure you are competent to handle the full capabilities of your bike.

Only use brakes designed to be mounted to the existing disc brake mount on the fork. Do not attempt to add any brake mount or use any brake device that requires adapting the fork’s existing brake mount. Altering or adapting the existing brake mount or installing new brake mounts will void the fork’s warranty and may result in structural failure of the fork. Structural failure of the fork will result in loss of control of the bicycle, placing the rider in danger of serious injury or death.

If the Lefty fork crowns are set with less than 110mm of clearance between the tire and the bottom of the lower crown, there is a risk of contact between the tire and the lower crown when the fork is completely compressed. If such tire / crown contact occurs while riding, the front

wheel could stop suddenly and throw the rider over the handlebars, with risk of serious injury or death.

HEADSHOK WARRANTY

All HeadShok forks and their internal assemblies are warrantied against manufacturing defects in materials and/or workmanship for a period of one year from the date of original retail purchase.

Not covered under warranty is damage resulting from improper adjustment or maintenance, lack of maintenance, crashes, or use judged by HeadShok to be excessive or abusive.

Please see your Cannondale Bicycle Owner’s Manual for more complete warranty information.

GETTING IN TOUCH WITH HEADSHOK

For warranty related questions or for more information on this or any HeadShok product, please feel free to contact us.

Europe (EC): (31) 541-573580
USA / Canada: (888) HEAD-SHK (432-3745)
Japan: (81) 722-99-9399
Australia: (61) 2-9979-5851

<http://www.headshok.com>
servicedeskeurope@cannondale.com

APPENDIX

List of HeadShok Lefty specific replacement parts kits:

HD220/	Replacement upper collar
HD221/	Replacement cartridge saddle, fits into axle spindle
HD222/	Replacement damper sleeve, for DLR and M only
HD300/	Replacement 9 volt lithium battery, for ELO only
HD301/	Replacement Electronic Control Unit, for ELO only