

2010



WARNING

**READ THIS SUPPLEMENT AND YOUR
CANNONDALE BICYCLE OWNER'S MANUAL.**

Both contain important safety information.
Keep both for future reference.

TOWNER'S M
MANUALS
SUPPLEMENT

LEFTY ULTRA 120
125227.PDF

cannondale[®]

In this supplement, particularly important information is presented in the following ways:



Indicates a hazardous situation which, if not avoided, could result in death or serious injury.

NOTICE

Indicates special precautions that must be taken to avoid damage.

TIP

A TIP provides helpful information.

This manual meets EN standards
14764, 14766, and 14781.

Vélo certifié conforme aux exigences du décret
N 95-937 du 24 août 1995 norme NFR030

Replacement Cannondale part numbers are shown throughout this supplement in **BOLD ITALIC** text.

2010 LEFTY ULTRA 120

Owner's Manual Supplement

125227.PDF

CONTENTS

SAFETY INFORMATION	2	XC3 STEM-STEERER	14
Intended Fork Use	2	1.125" STEERER	16
Fork Damage.....	3	MAINTENANCE	18
IDENTIFICATION	4	Cleaning	19
LEFTY WHEEL HUB	5	Frame Bumper	19
SPECIFICATIONS		Boot Inspection.....	20
Lefty Ultra 120 Carbon SI w/PBR	6	Clean/Re-Oil Air Filter	21
Lefty Ultra 120 w/PBR.....	7	<i>LEFTY NEEDLE BEARING RESET</i>	22
Lefty Ultra 120 w/DLR.....	8	PBR Needle Bearing Reset.....	24
PBR ADJUSTMENT	9	DLR Needle Bearing Reset.....	25
DLR ADJUSTMENT	11	Clean/Re-Grease Telescope	26
FRONT WHEEL	12	REPLACEMENT PARTS	27
Removal	12		
Installation	13		



WARNING

This supplement may include procedures beyond the scope of general mechanical aptitude. Special tools, skills, and knowledge may be required. Improper mechanical work increases the risk of an accident. Any bicycle accident has risk of serious injury, paralysis or death. To minimize risk we strongly recommend that owners always have mechanical work done by an authorized Cannondale retailer.

Please note that the specifications and information in this manual are subject to change for product improvement. For the latest product information, go to http://www.cannondale.com/tech_center/

SAFETY INFORMATION

INTENDED FORK USE

Lefty ULTRA 120 forks are intended for use in Condition 4 (All Mountain) riding. The CONDITION 4 symbol is shown next figure.



Figure 1.

CONDITION 4

Bikes designed for riding Conditions 1, 2, and 3, plus rough technical areas, moderately sized obstacles, and small jumps.

Fork is Intended

For trail and uphill riding. All-Mountain bicycles are: (1) more heavy duty than cross country bikes, but less heavy duty than Freeride bikes, (2) lighter and more nimble than Freeride bikes, (3) heavier and have more suspension travel than a cross country bike, allowing them to be ridden in more difficult terrain, over larger obstacles and moderate jumps, (4) intermediate in suspension travel and use components that fit the intermediate intended use, (5) cover a fairly wide range of intended use, and within this range are models that are more or less heavy duty. Talk to your retailer about your needs and these models.

Fork Not Intended

This fork is not intended for use in extreme forms of jumping/riding such as hardcore mountain, Freeriding, Downhill, North Shore, Dirt Jumping, Slope-style, Hucking etc.

WARNING

UNDERSTAND YOUR FORK AND ITS INTENDED USE.

USING YOUR FORK THE WRONG WAY IS DANGEROUS.

Industry usage Conditions 1 - 5 are generalized and evolving. Consult your Cannondale Dealer about how you intend to use your bike.

Please read your *Cannondale Bicycle Owner's Manual* for more information about Intended Use and Conditions 1-5.

FORK DAMAGE

WARNING

STOP RIDING A DAMAGED FORK IMMEDIATELY.

The following conditions indicate that serious fork damage is present:

1. Any unusual "klunking" or knocking noises.
2. A change in fork travel.
3. An over-extended, elongated, or compressed boot.
4. Changes from the way the fork had been working
5. Loss of adjustment features, oil leaks, or air leaks.
6. Crash or impact damage (deep scratches, gouges, dents, or bending)
7. Small cracks under the bolt head of upper and lower clamp bolts. This inspection requires the removal of the bolts.

Horizontal cracks above and below the intersection of the upper and lower clamps with the outer tube portion of the Lefty carbon structure.

Vertical cracks in the outer tube (where the races and needle bearings run). These may show as long, straight lines perhaps several lines parallel to each other.

Also, please read Inspect For Safety in PART II, Section D. of your *Cannondale Bicycle Owner's Manual*.

HAVE ANY DAMAGED FORK INSPECTED AND DAMAGE REPAIRED BY YOUR CANNONDALE DEALER. YOU CAN BE SEVERELY INJURED, PARALYZED OR KILLED IN AN ACCIDENT IF YOU IGNORE THIS WARNING.

The **MAINTENANCE** section of this supplement includes information about regular maintenance practices that can keep your fork in good operating condition.

IDENTIFICATION

LEFTY WHEEL HUB

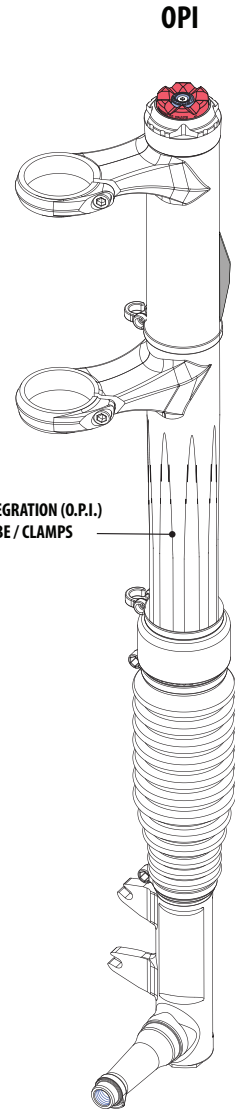
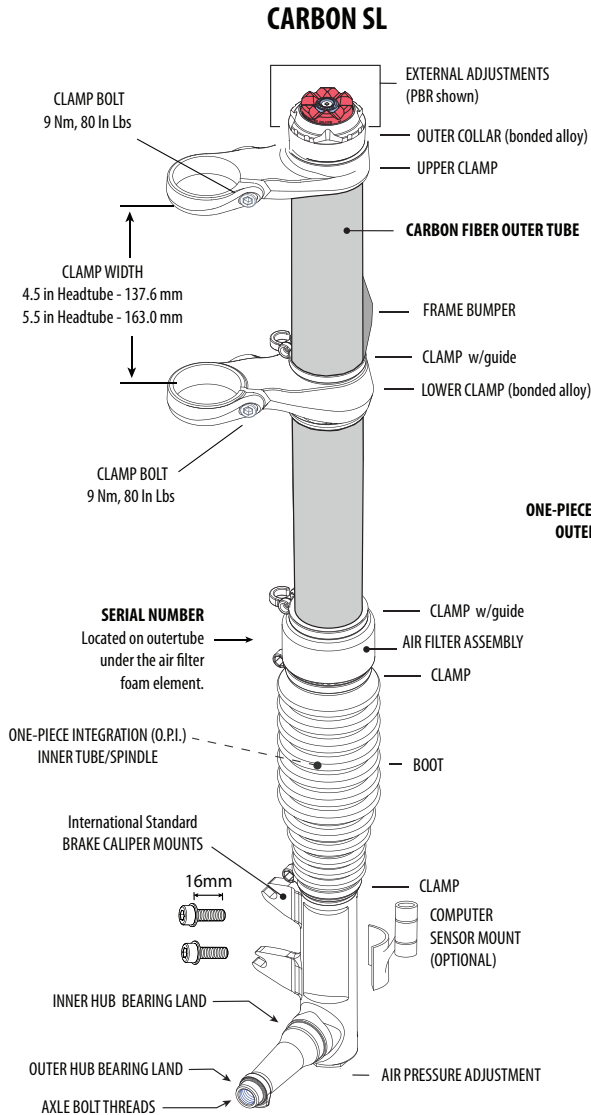

LEFTY 24 AND 32 SPOKE HUB DIMENSIONS	
DISC FLANGE DIAMETER	58MM
NON DISC FLANGE DIAMETER	44.5MM
DISC FLANGE TO CENTER	35MM
NON DISC FLANGE TO CENTER	20MM

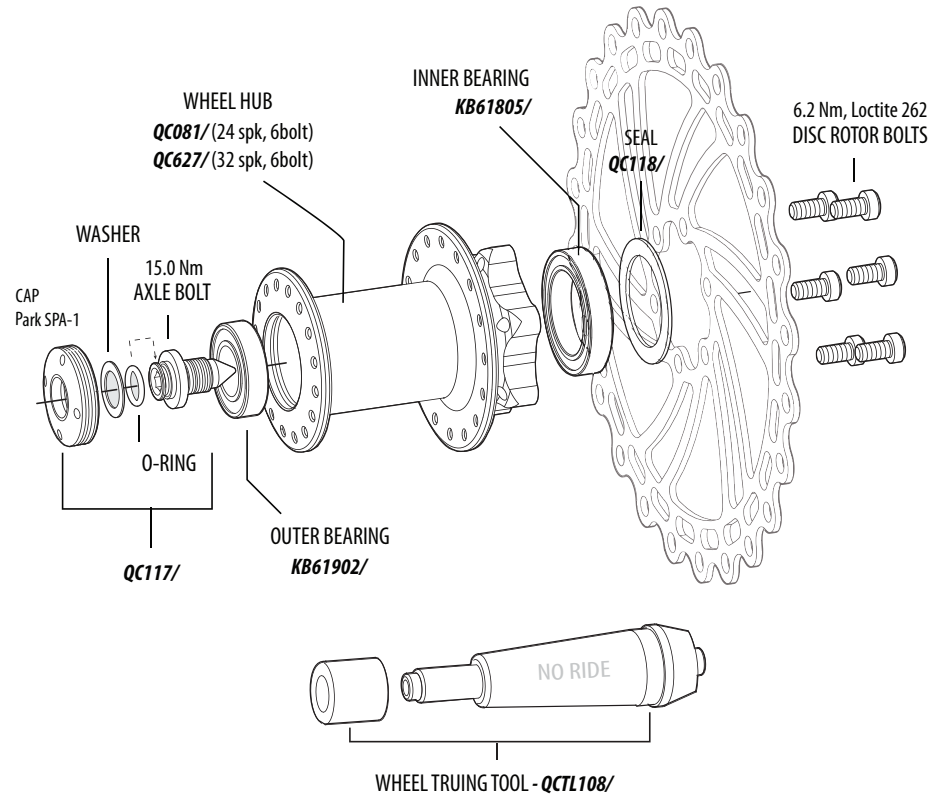

SPECIFICATIONS

Lefty Ultra 120 Carbon SL w/PBR

Integrated Frame Design	RZ One Twenty
Intended Use	CONDITION 4, Marathon
Travel (mm)	120
	Pop-Top, On/Off
	Rebound
Adjustments	Air Pressure Limits:
	MINIMUM. 50 psi, 3.4 bar
	MAXIMUM. 225 psi, 15.5 bar
Recommended Sag 25 %	30 mm
Spring Type/Material	Solo Air
Negative Spring	Air Automatic
Damper	PBR w/Pop Top
Damper Oil Volume	--
Damper Oil Weight	5w
Telescope Length (Needle Bearing Reset)	720 - 730 mm
Clamp Width	STANDARD - 137.6 mm, 4.5 In Headtube
	XL - 163.0 mm, 5.5 In Headtube
Weight Lbs. (gr)	2.75 (1245)



Lefty Ultra 120 w/PBR

Integrated Frame Design	RZ One Twenty
Intended Use	CONDITION 4, Marathon
Travel (mm)	120
	Pop-Top, On/Off
	Rebound
Adjustments	Air Pressure Limits:
	MINIMUM. 50 psi, 3.4 bar
	MAXIMUM. 225 psi, 15.5 bar
Recommended Sag 25 %	30 mm
Spring Type/Material	Solo Air
Negative Spring	Air Automatic
Damper	PBR w/Pop Top
Damper Oil Volume	--
Damper Oil Weight	5w
Telescope Length (Needle Bearing Reset)	720 - 730 mm
Clamp Width	137.6 mm, 4.5 In Headtube
Weight Lbs. (gr)	3.08 (1395)



Lefty Ultra 120 w/DLR

Integrated Frame Design	RZ One Twenty
Intended Use	CONDITION 4, Marathon
Travel (mm)	120
Adjustments	Lockout, On/Off
	Rebound
	Air Pressure Limits:
	MINIMUM. 50 psi, 3.4 bar
	MAXIMUM. 225 psi, 15.5 bar
Recommended Sag 25 %	30 mm
Spring Type/Material	Solo Air
Negative Spring	Air Automatic
Damper	DLR
Damper Oil Volume	--
Damper Oil Weight	5w
Telescope Length (Needle Bearing Reset)	720 - 730 mm
Clamp Width	STANDARD - 137.6 mm, 4.5 In Headtube
Weight Lbs. (gr)	3.09 (1400)



PBR ADJUSTMENT

Rebound

The red rebound knob has two functions:

1. **ROTATE TO CONTROL REBOUND.**

Turn in the -- direction (counter-clockwise) to increase rebound speed (faster).

Turn in the + direction (clockwise) to decrease rebound speed (slower).

2. **PRESS DOWN TO DISENGAGE POP TOP.**

Rebound can be adjusted in or out of POP TOP.

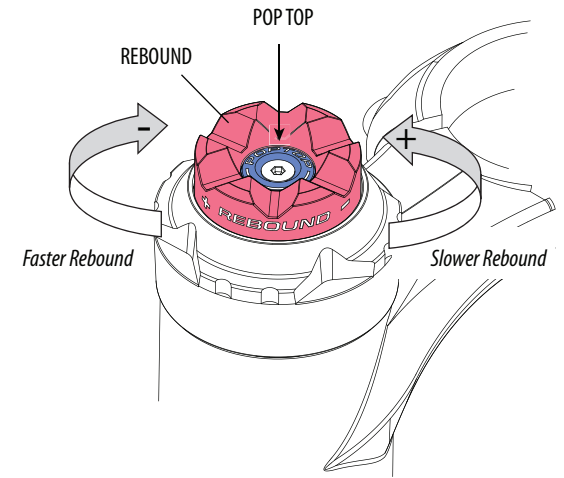

Pop Top

Press the blue button in the center of the rebound knob to engage the POP TOP feature. Riders will feel a firm threshold which offers great efficiency for climbing and smoother trails.

Press down the red rebound knob to disengage the threshold.

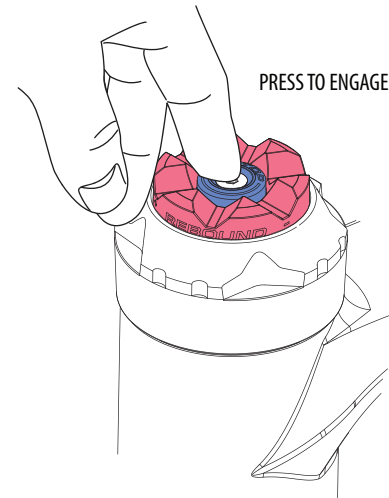

WHEN POP TOP IS ENGAGED, THE REBOUND KNOB IS RAISED.

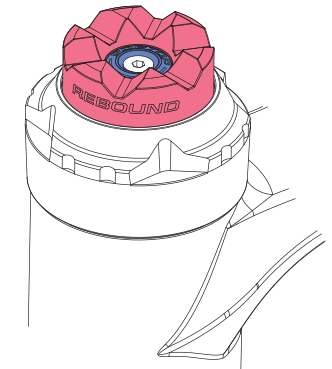

Recommended Air Pressure

To set air pressure

1. Make sure the bottom of the fork is clean. Remove the Schrader valve cap. Attach a bicycle suspension pump to the valve end. Pressurize the fork according to the table.

RIDER (Lbs/Kg)		STARTING PRESSURE (psi, bar)	
75	34	45	3.1
100	45	60	4.1
125	57	75	5.2
150	68	90	6.2
175	80	105	7.2
200	91	120	8.2
225	102	135	9.3
250	114	149	10.3
275	125	164	11.3

RECOMMENDED SAG 25%
30 mm

PRESSURE LIMITS
Minimum: 50 psi, 3.4 bar
Maximum: 225 psi, 15.5 bar

2. Now, to fine tune the sag. Without a rider, measure the fork from the bottom edge of the outer collar to the bottom edge of the spindle. Next, have someone assist you. Sit on the bike with your feet on the pedals and hands on handlebar as if you were in a riding position; measure length (B), the fork compressed under your weight.

To calculate the sag, subtract : $A - B = \text{SAG (mm)}$.

Add air pressure to decrease sag.

Release air pressure to increase sag.

NOTICE

MAKE SURE THE SUSPENSION PUMP AND FORK SCHRADER VALVE ARE CLEAN. Attaching to a dirty valve or with a dirty pump end can result in pumping the dirt into the fork. This could result in damage and air loss.

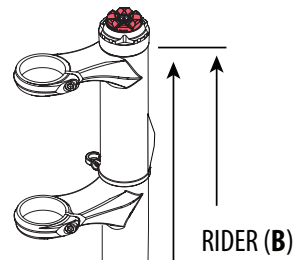
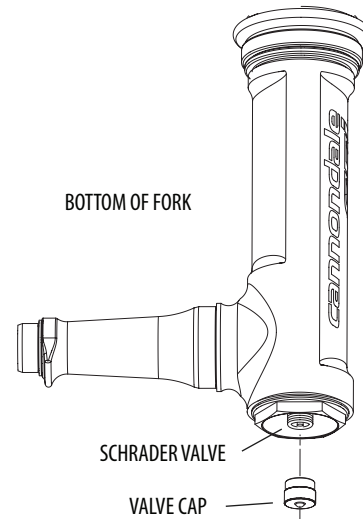

NO RIDER (A)

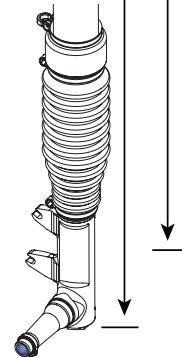

$\text{SAG} = A - B$

DLR ADJUSTMENT

Rebound

The red rebound dial at the top of the fork controls rebound speed, how fast the fork extends following compression. Turn the dial clockwise (the "+" direction) for slower rebound. Turn the dial counter-clockwise (the "-" direction) for faster rebound.

Lockout

Rotate the lockout lever clockwise to lock fork travel. Rotate the lever counter-clockwise to unlock fork travel. When rotating the lever, rotate it completely to the stop points.

Recommended Air Pressure

1. Make sure the bottom of the fork is clean. Remove the Schrader valve cap. Attach a bicycle suspension pump to the valve end. Pressurize the fork according to the table.

RIDER (Lbs/Kg)		STARTING PRESSURE (psi, bar)	
75	34	45	3.1
100	45	60	4.1
125	57	75	5.2
150	68	90	6.2
175	80	105	7.2
200	91	120	8.2
225	102	135	9.3
250	114	149	10.3
275	125	164	11.3

RECOMMENDED SAG 25% 30 mm

PRESSURE LIMITS Minimum: 50 psi, 3.4 bar, Maximum: 225 psi, 15.5 bar

2. Now, to fine tune the sag. Without a rider, measure the fork from the bottom edge of the outer collar to the bottom edge of the spindle. Next, have someone assist you. Sit on the bike with your feet on the pedals and hands on handlebar as if you were in a riding position; measure length (B), the fork compressed under your weight. To calculate the sag, subtract : $A - B = \text{SAG (mm)}$. Add air pressure to decrease sag. Release air pressure to increase sag.

NOTICE

MAKE SURE THE SUSPENSION PUMP AND FORK SCHRADER VALVE ARE CLEAN. Attaching to a dirty valve or with a dirty pump end can result in pumping the dirt into the fork. This could result in damage and air loss.

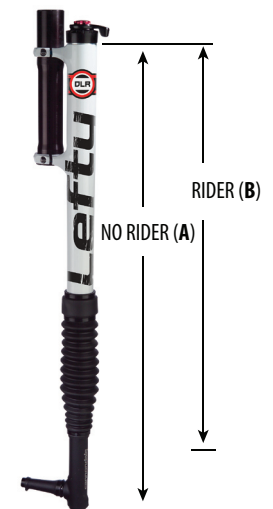
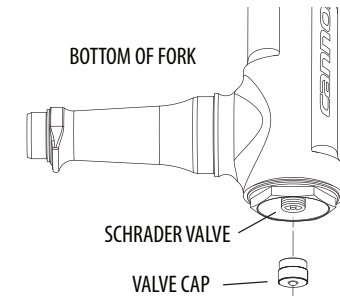
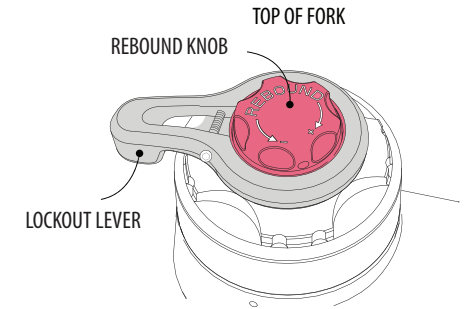

$\text{SAG} = A - B$

FRONT WHEEL

Removal

- 1 Loosen the brake caliper mounting bolts.

Tilt the lower caliper bolt out of the boss so the caliper is up out of the way of the disc. Snug up on the upper bolt to hold caliper in place.

Take note of brake alignment shims between brake bosses and the caliper. Be sure to reposition correctly.

2. Turn the hub extraction bolt counter-clockwise (ccw) to remove the wheel.

NOTICE

- Make sure the bolt is completely disengaged before attempting to remove the wheel. Never try to pull the wheel off forcefully.
- When the wheel is off, to keep dirt out, cover the hub opening.
- Protect spindle from damage when wheel is removed.

Continue turning the bolt until the wheel can be removed easily from the spindle.

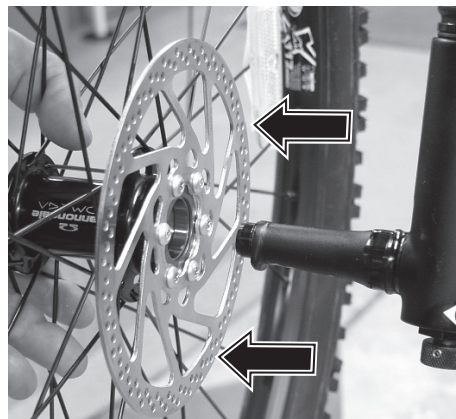
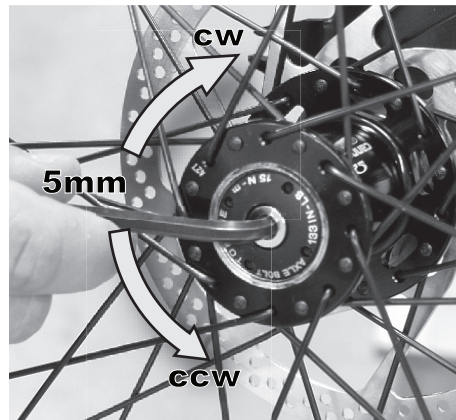

Installation

1. Inspect inside the wheel hub for contamination and the condition of the hub seal. Take corrective action if necessary.

Wipe the spindle clean with a dry shop towel and apply a high-quality bike grease to the spindle bearing lands and end threads.

2. Slide the wheel straight onto the spindle so, the larger hub bearing starts to position on it spindle seat. At this point, the axle bolt threads can correctly engage the threaded spindle if the wheel is held on straight.

NOTE: Install the front wheel by positioning the bike horizontally with the spindle facing up. Then place the hub straight down onto the spindle, and tighten the axle bolt.

3. When the axle bolt threads engage the spindle, turn the bolt clockwise with finger force slowly to allow the hub bearings to slide onto the spindle bearing seats.

Once the hub has been drawn onto the hub completely, use torque wrench to tighten to final 15.0 N·m (133.0 In·Lbs).

4. Reinstall the brake caliper. Tighten bolts to 78.0 In·Lbf (9.0 N·m).
5. Spin the wheel to make sure it moves freely. Be sure to test the brakes for proper operation before riding.

WARNING

DO NOT CONTAMINATE BRAKE CALIPER, PADS, OR ROTOR WITH GREASE.

WARNING

DO NOT RIDE WITHOUT A PROPERLY MOUNTED, ADJUSTED, AND FUNCTIONING FRONT BRAKE SYSTEM.

The Lefty (disc/caliper) acts as an integral secondary wheel retention system. If the system is missing or improperly installed, or if the wheel hub axle bolt should loosen, the front wheel could slide off the spindle end.

When mounting IS compatible brake systems:

Follow brake manufacturer's instructions when mounting the brake caliper to the spindle brake bosses. Do not modify the fork in any way.

PLEASE ASK YOUR CANNONDALE DEALER FOR HELP WHEN INSTALLING COMPATIBLE FRONT BRAKE SYSTEMS.

NOTICE

- **LOCATE BRAKE ROTOR BETWEEN THE PADS.** Replace shims that are in use, be sure the shims are positioned between the caliper (adapter if any) and inner face of the fork mounts, not under the head of the caliper bolts.
- **USE ONLY THE LEFTY 16mm CALIPER BOLTS TO MOUNT THE BRAKE.** Longer bolts can result in contact with the brake rotor causing severe damage. Check clearance between the bolt tips and rotor after remounting the caliper. Order replacement bolts - Cannondale p/n **LEFTYBOLTS/**.
- **MAKE SURE THE BRAKE DISC CAN NOT MAKE CONTACT WITH THE FORK BOOT.** A rotating brake disc can wear through the boot allowing contaminants into the fork.

XC3 SI STEM STEERER

The following procedures should only be completed by a professional bike mechanic.

Installation

1. Loosen both clamp bolts.
2. Position the Lefty clamps onto the headtube assembly as shown.
NOTE: Be sure to route the front brake line between Lefty and Headtube when mounting the fork.
3. Insert Cannondale tool *KT020/* (a.k.a. "Ernie") through the bottom clamp, into the head tube, and out the upper clamp. The tool aligns and guides the steerer. Its really quite effective! See the graphic?
4. Use a rubber mallet to drive the stem-steerer into the head tube until it stops.
5. Clean and apply grease to the steerer bolt threads and install into the bottom of the stem-steerer. This is an important step. **Don't forget the grease!**

Align handlebar and tighten the steerer bolt to 9 N·m.

6. Tighten the upper and lower clamp bolts to 9 N·m.

Removal

Once again, make sure you have the Ernie.

1. Loosen upper and lower clamp bolts.
2. Remove steerer bolt. Use a 5mm Allen key; turn counter-clockwise.
3. Insert the small end of *KT020/* into the bottom of the stem-steerer, hold the LEFTY, and drive the stem-steerer up out of the head tube.

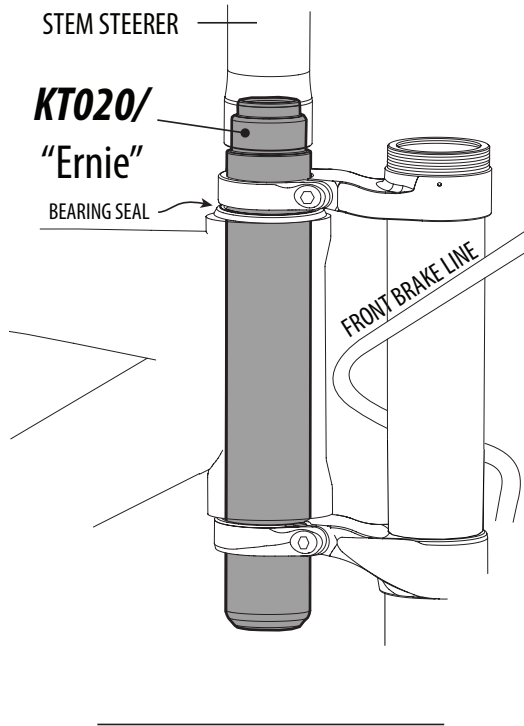

"NOW THAT'S AN AWESOME TOOL!"

STEM SIZE MARKING

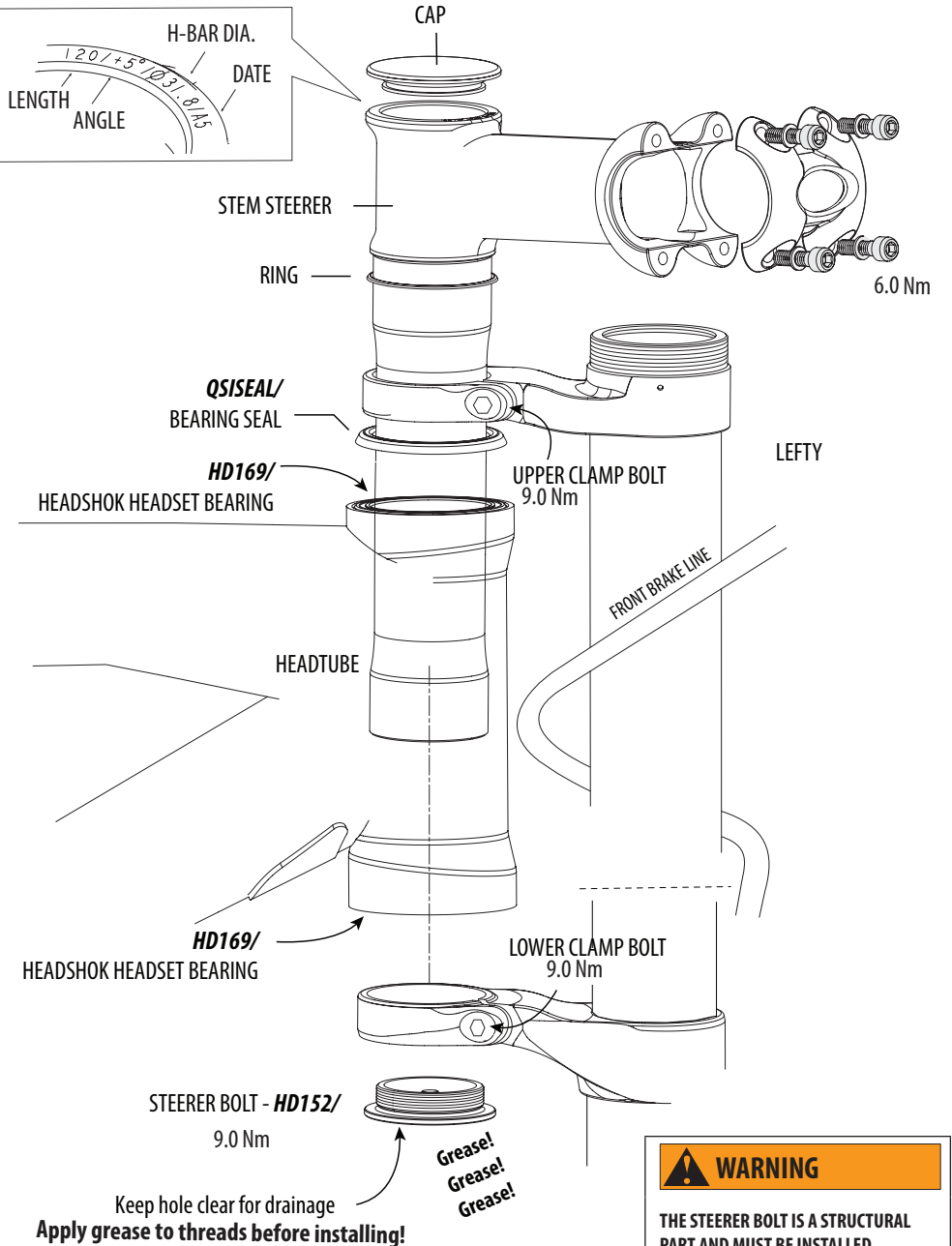
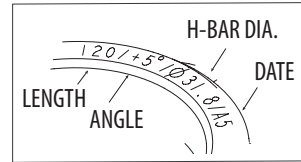

1.125" STEERER

The 1.125" steerer adapter assembly enables fork installation into a compatible 1.125" head tube frame. Three different headset kit are available. **The adapter system must be installed by a professional bike mechanic.**

- The LOWER REDUCER must be inserted completely into the lower clamp.
- The upper clamps should only clamp to the UPPER REDUCER as it is designed to compress onto the 1.125 in STEERER. Clamping on SPACERS will result in insufficient clamping force.
- Locate the upper reducer slot 180° opposite the Lefty upper clamp slot.
- Install a combination of adapter kit spacers (5 mm, 10 mm, and 20 mm) to close the gap between the headset top cap and the upper reducer.
- Install all handlebar stem spacers above the upper reducer.
- Tighten the upper and lower Lefty Clamp bolts AFTER the stem top cap has been installed and preload set. Tighten the Lefty Clamp bolts to 9 Nm, 80 In Lbs.

CANNONDALE KIT	HEADSET STACK HEIGHTS		STANDARD Lefty Clamp Width	XL Lefty Clamp Width
	KH058/ w/ Standard headset	Upper cup	13.8 mm	Headtube ≤ 112.3 mm
	Lower cup	11.5 mm		
	Total	25.3 mm		
KH059/ w /Zero Stack headset	Upper cup	11.3 mm	Headtube ≤ 124.3 mm	Headtube ≤ 149.7 mm
	Lower cup	2 mm		
	Total	13.3 mm		
KH060/ w/ Hiddenset headset	Upper cup	10 mm	Headtube ≤ 127.1 mm	Headtube ≤ 152.5 mm
	Lower cup	0.5 mm		
	Total	10.5 mm		

⚠ WARNING

Before installing the adapter system, YOU must confirm with the frame manufacturer that the frame can be safely used with the adapter system and fork. This is YOUR responsibility and important to your safety.

A long travel fork may create too much force on a frame designed for a shorter fork.

If you ignore this warning, then the frame can break while your are riding it. YOU CAN BE SEVERELY INJURED, PARALYZED OR KILLED IN A RESULTING ACCIDENT.

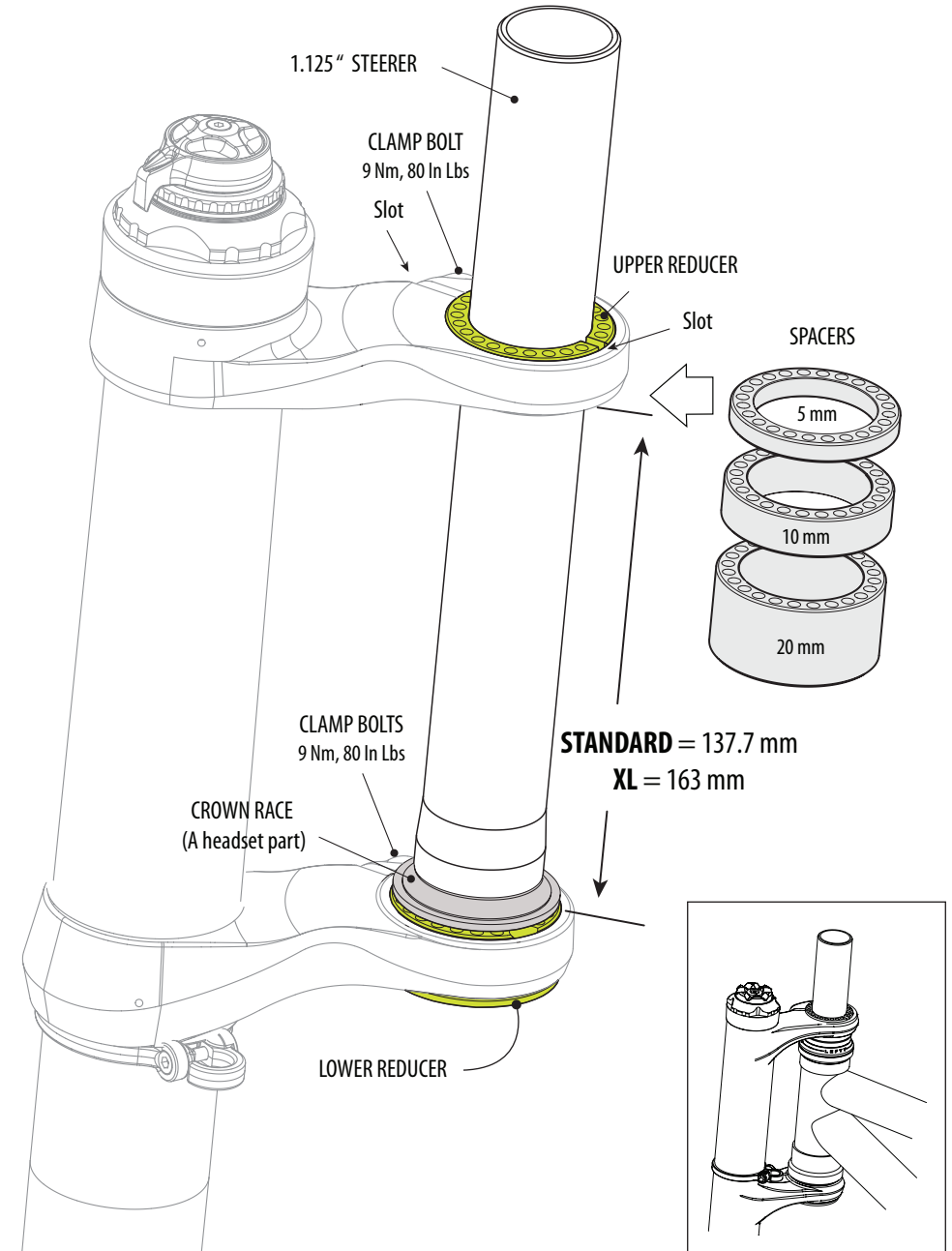

MAINTENANCE

This schedule is intended as a guide only. You must establish a schedule appropriate to your riding style and conditions.

WHAT TO DO	NORMAL	RACE
	(In Hours)	
CHECK FOR DAMAGE - See page 3.	BEFORE AND AFTER EVERY RIDE	
BOOT INSPECTION - See page 20.		
TIGHTENING TORQUE CHECK - Use a torque wrench: Upper/lower clamp bolts: 9.0 Nm, 80 In Lbs Wheel axle bolt: 15.0 Nm, 133.0 In Lbs	AFTER FIRST RIDE CHECK EVERY 4-5 RIDES	
CLEAN/RE-OIL AIR FILTER - See page 21.	25	10
CLEAN/ RE-GREASE TELESCOPE - See page 26.	50	25
NEEDLE BEARING RESET * See page 22.	25	25
Damping cartridge oil and seal change *	100	25
Inspect, replace frame bumper See page 19.	AS NEEDED	
SCHEDULE PROFESSIONAL FORK SERVICE * ANNUALLY (Minimum) Annually, or when problems are indicated you must have your Lefty fork serviced through a Cannondale Dealer or an Authorized Headshok Service Center. Your fork should be disassembled by a suspension professional and evaluated for internal and external part wear and damaged parts replaced with new ones. It should also include any work described in any technical bulletins or product recalls. PLEASE NOTE: Cannondale provides professional services through Cannondale dealers for Headshok /Lefty suspension forks. Please ask your dealer about the service programs available for your model fork.		

WARNING

FREQUENT MAINTENANCE AND INSPECTION IS IMPORTANT TO YOUR SAFETY. YOU CAN BE SEVERELY INJURED, PARALYZED OR KILLED RIDING ON A BROKEN OR POORLY MAINTAINED FORK. Ask your Cannondale Dealer to help you develop a complete fork maintenance program, one that suits where and how you ride.

IMPORTANT INFORMATION ABOUT RIDING IN WET, HUMID, OR COASTAL CONDITIONS

Before and after rides, frequently, inspect and renew grease under fork boot and service the air filter. Inspect the boot for rips and tears. Check the folds. If the boot is damaged or not attached securely by the clamps/zip ties, water or contaminants can enter. The boot should be removed and the fork should be immediately dried and re-greased to stop any damage occurring due to moisture.

ANYTIME THE FORK BECOMES SUBMERGED

Stop riding it. The fork is not water tight. A moving submerged fork can accumulate water inside. If your fork has been submerged, you should perform checks immediately.

DO NOT STORE YOUR LEFTY FOLLOWING A WET RIDE WITHOUT FIRST PERFORMING THE CHECKS ABOVE. SERIOUS DAMAGE CAN OCCUR.

Cleaning

Clean using only a mild soap and water solution. Clean water and common liquid dish washing soap will work best. Be sure to cover the adjusters with a clean plastic bag secured with a rubber band or masking tape. Spray off heavy dirt before wiping. Spray indirectly.

NOTICE

- **DO NOT USE A PRESSURE WASHER.** Use a low pressure garden hose. Power washing will force contaminants into the fork promoting corrosion, immediately damaging, or result in accelerated wear.
- **DON'T DRY WITH COMPRESSED AIR FOR THE SAME REASON.**

Frame Bumper

The Lefty frame bumper is located on the outer tube between the clamps. The bumper cushions the frame from contact with the fork. Replace it with a new one if it ever becomes damaged, torn, or missing.

BUMPER PLACEMENT: The bumper should be positioned on the Lefty so that the bumper contacts frame with handlebars turned to the left.



Boot Inspection

The fork boot protects the internal parts (inner tube, races, lubricant, needle bearings, and other internal parts) from contamination and damage. It is a barrier to water, dirt, dust, mud, or grit encountered while riding. If the boot is loose or damaged, dirt, water, dust, salt spray or other contaminants will quickly ruin the fork.

The boot is an important protection, so before every ride do the following:

1. Check the boot for damage cracking, splits, or tears. Be sure to check in the folds of the boot.
Check carefully in the folds.
Check for any cables or lines rubbing the boot.
Make sure the brake rotor does not rub or contact the boot.
2. Check the attachment of the boot at the top and bottom. The upper and lower boot lips should be fitted over the lower collar and fork lip. **NO PART OF THE FORK INNER TUBE (lower leg) SHOULD BE EXPOSED.**
3. Replace clamps as required. Always tighten securely, but do not over-tighten the clamps. Replacement cable clamps are available through a Cannondale Dealer.

IMPORTANT:

If you find boot damage, the area under the fork should also be inspected for damage. And, the damaged boot must be replaced with a new one before riding. Do not try to fix it.



Clean/Re-Oil Air Filter

The air filter assembly is located over breather air holes in the outer tube. The air filter assembly stops the passage of dirt and water which would damage the internal fork components.

The cleaning procedure is the same for carbon or alloy outer tube fork

To clean and re-oil air filter

1. Loosen and remove both the upper and lower clamps.
Return the lower clamp to the top of the boot and secure it to seal out water.
2. Slide the air filter cover up off the foam element.
3. Slide the foam element up off the breather hole.
4. Cover the breather hole by applying a ring of vinyl tape around the tube.
5. Using warm clean soapy water, massage the foam air filter element. Preventing water or soap from entering the holes in the outer tube or into top of the boot. This will clean the foam of accumulated dirt or dust.
6. Repeat the process with clean warm water to rinse the foam. Gently squeeze the foam element to remove the water.
7. Allow the foam element to dry completely, and massage in a high-quality foam air filter oil.
8. Slide the foam element back into position over the breather hole.
9. Slide the boot back over the foam element. The lower filter cover lip should be lapped over the top of the boot. The small holes in the filter cover should be positioned on the fork so they are at the sides to prevent plugging from dirt or debris thrown by the front wheel.

NOTICE

- DO NOT USE SPRAY CLEANERS.
- COVER BREATHER HOLE. MAKE SURE THE BOOT LOWER CLAMP IS SECURE.

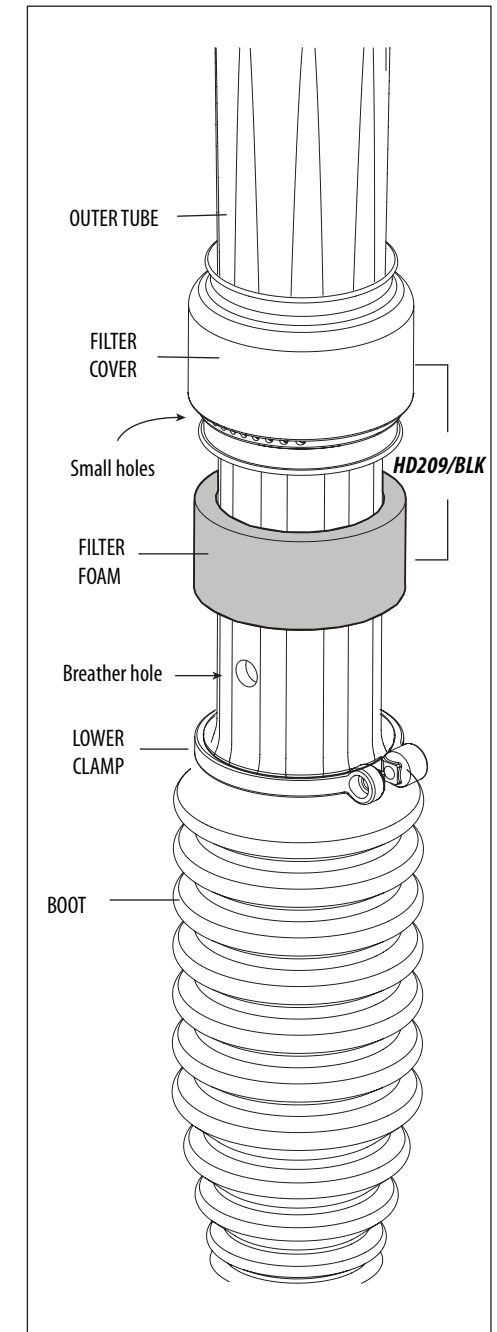

LEFTY NEEDLE BEARING RESET

The unique advantage of the Lefty telescopic fork structure is the utilization of 4 needle bearing cages. Each cage contain 22 precision stainless steel needle bearings. The use of needle bearings requires less surface area to make the telescope perform smoothly and efficiently. This is accomplished through rolling versus sliding and results in less friction. Less friction means smoother travel, pure and simple. Compare that with conventional forks that use bushings in their stanchions. These bushings have more contact with the sliding part of the scope, which generates friction. That friction causes a heat build-up within the fork and robs performance.

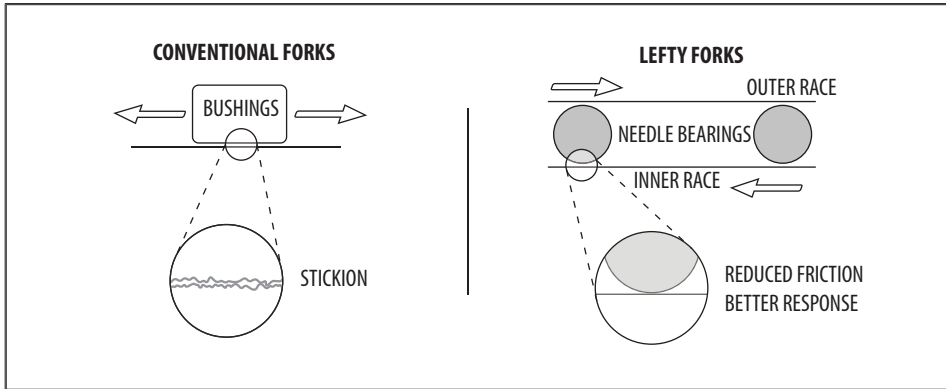

The system requires simple periodic maintenance to ensure proper bearing alignment. Why? Inside the fork the four needle bearing cages of the telescope move independently up and down between each inner and outer race pair. Bearing cage migration happens when a cage or cages shifts out of alignment up or down in relation to the others. Very slight migration would not affect travel noticeably, however, as a cage continues to move out of position relative to the others, the available travel will be reduced.

Needle bearing migration is normal and to be expected. However, if the fork in this state for extended periods, the fork can be damaged. Indications of migration are: An usual "top out" noise, reduced travel.

Resetting Needle Bearing Migration

The procedure for resetting your specific Lefty needle bearings is described in the section of the supplement specific to your fork. The techniques of resetting is the same for all forks, however, dis-engaging the damping cartridge differs. We provide the information in the supplement, however, we recommend that you always have this procedure performed by your Cannondale Dealer. If migration re-occurs frequently (immediately after resetting), the cause could be damage present in the inner or outer races, bearings/cages or other fork parts. Inspection and replacement of damage parts will be required to correct a persistent problem with bearing migration.

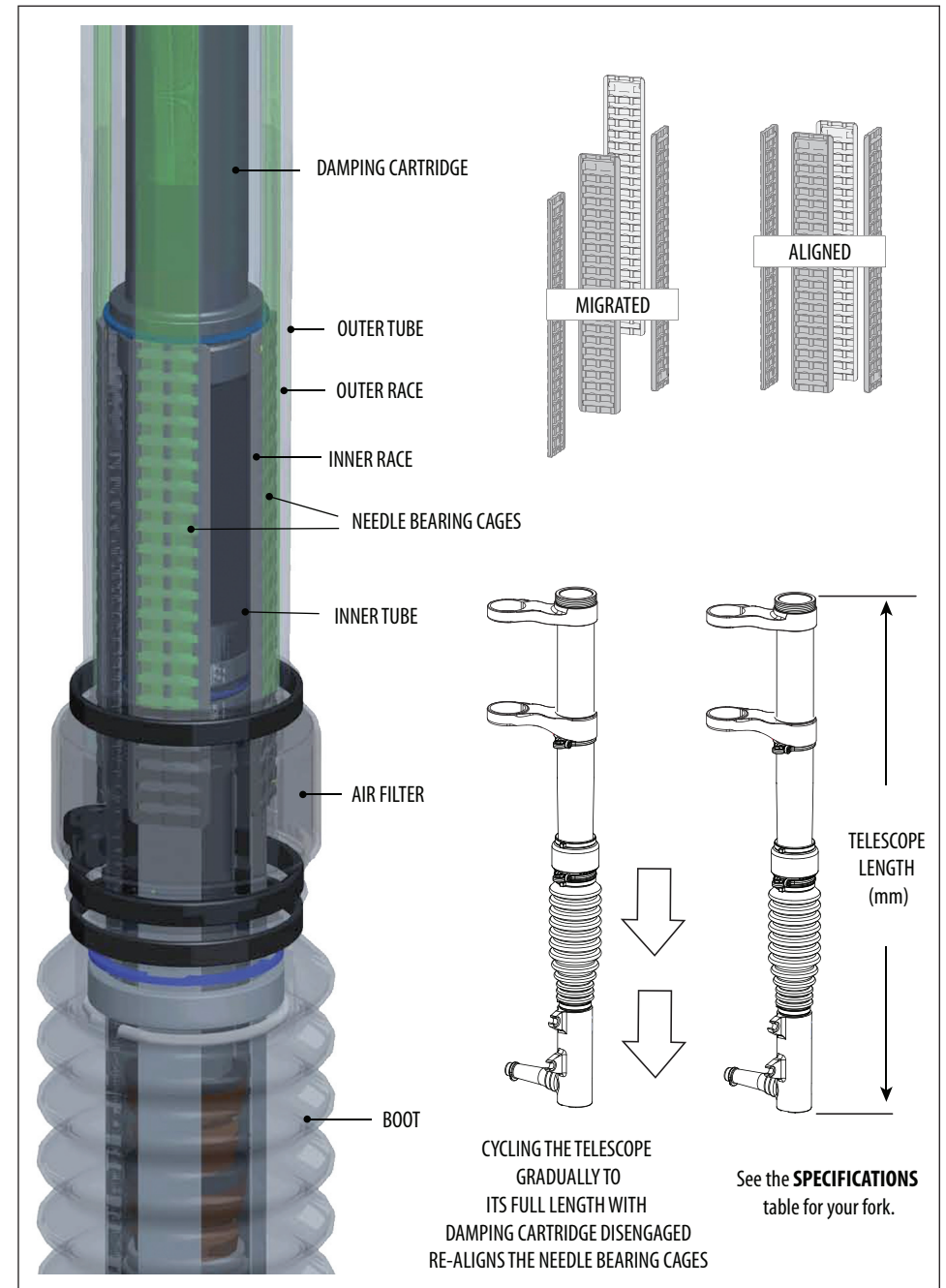

PBR Needle Bearing Reset

The following procedure should only be completed by a professional bike mechanic.

See **LEFTY NEEDLE BEARING RESET** on page 14.

To reset

1. Release all air pressure through Schrader valve in bottom of fork.
2. Remove the outer collar with the Shimano tool TL-FC32. Turn counter-clockwise.
3. Compress the telescope and remove the two split rings from the top cap.
4. Fully extend the fork, and measure from top edge of outer tube to bottom edge of spindle. See right. If the length is out of specification do the following:

Firmly extend the telescope until it stops (tip - listen for the knocking at full extension to change from a hollow sound to a solid sound - this indicates full extension has been achieved). Do this several times using only moderate force, extend the lower fork leg using a pumping action.

After, you have performed this action several times, re-measure.

NOTICE

If fork is out of range following reset attempt, it may be damaged internally. The fork should be disassembled and inspected by a professional mechanic before it is ridden.

TIP: If migration re-occurs frequently (immediately after resetting), the cause could be damage present in the inner or outer races, bearings/cages or other fork parts. Inspection and replacement of damage parts will be required to correct a persistent problem with bearing migration.

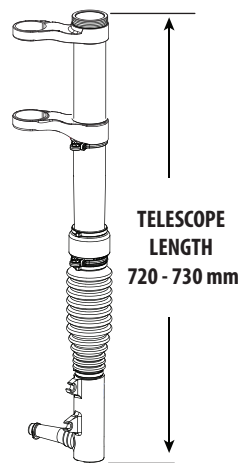
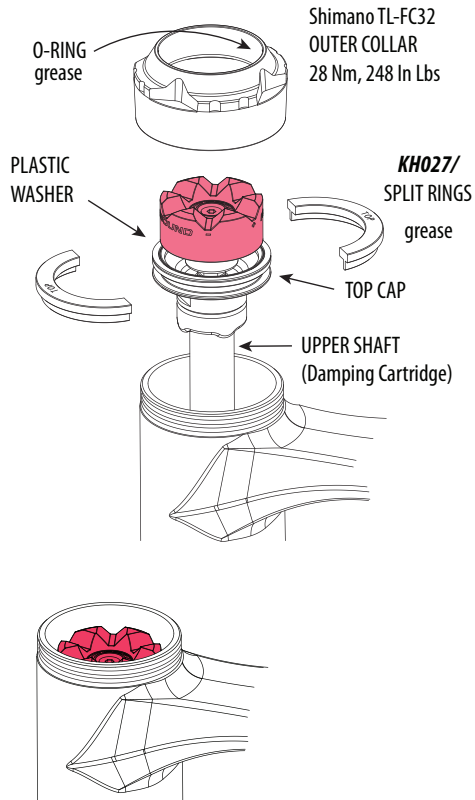

DLR Needle Bearing Reset

The following procedure should only be completed by a professional bike mechanic.

See **LEFTY NEEDLE BEARING RESET** on page 14.

To reset

1. Release all air pressure through Schrader valve in bottom of fork.
2. Loosen the lockout lever retaining screw and lift off the lockout lever. Note the lever position so it can be replaced to the same position later.
3. Remove the outer collar with the Shimano tool TL-FC32. Turn counter-clockwise.
4. Compress the telescope and remove the two split rings from the top cap.
5. Fully extend the fork, and measure from top edge of outer tube to bottom edge of spindle. See right. If the length is out of specification do the following:

Firmly extend the telescope until it stops (tip - listen for the knocking at full extension to change from a hollow sound to a solid sound - this indicates full extension has been achieved). Do this several times using only moderate force, extend the lower fork leg using a pumping action.

After, you have performed this action several times, re-measure.

NOTICE

If fork is out of range following reset attempt, it may be damaged internally. The fork should be disassembled and inspected by a professional mechanic before it is ridden.

TIP: If migration re-occurs frequently (immediately after resetting), the cause could be damage present in the inner or outer races, bearings/cages or other fork parts. Inspection and replacement of damage parts will be required to correct a persistent problem with bearing migration.

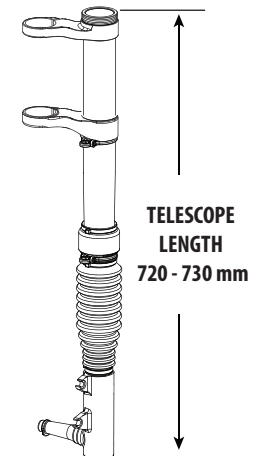
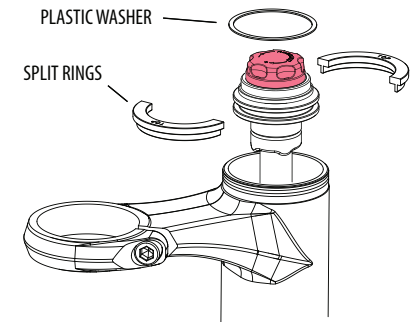

Clean/Re-Grease Telescope

Periodically, or whenever the fork is ridden in extreme conditions or is submerged, perform the following procedure.

To clean and re-grease

1. Remove the front wheel.
2. Carefully release the upper and lower zip ties securing the fork boot. If the boot is secured with a band clamp, loosen and remove the clamp.
3. Lift the unsecured boot up to expose the inner tube.
4. Wipe off the old grease with a dry shop towel.
5. Re-apply a fresh heavy coating of grease. Any clean high-quality bicycle bearing grease selected for riding temperatures and environment can be used.

*We assemble forks at our factory using
LUBRIPLATE GR-132.*

http://www.lubriplate.com/pdf/pds/3_4%20GR-132.pdf

Cycle the fork several times between applying grease to the new grease is worked into the bearings.

6. Reposition the boot and replace the upper and lower clamps.

NOTICE

- DO NOT USE SPRAY CLEANERS OR ABRASIVES. USE A CLEAN SHOP TOWEL ONLY.

NOTE: Make sure the clamps are secure without over-tightening. A loose clamp may allow water or dirt to pass behind the boot. If the clamps are too tight, boot damage can occur.

HD225/

KIT, GREASE, LUBRIPLATE

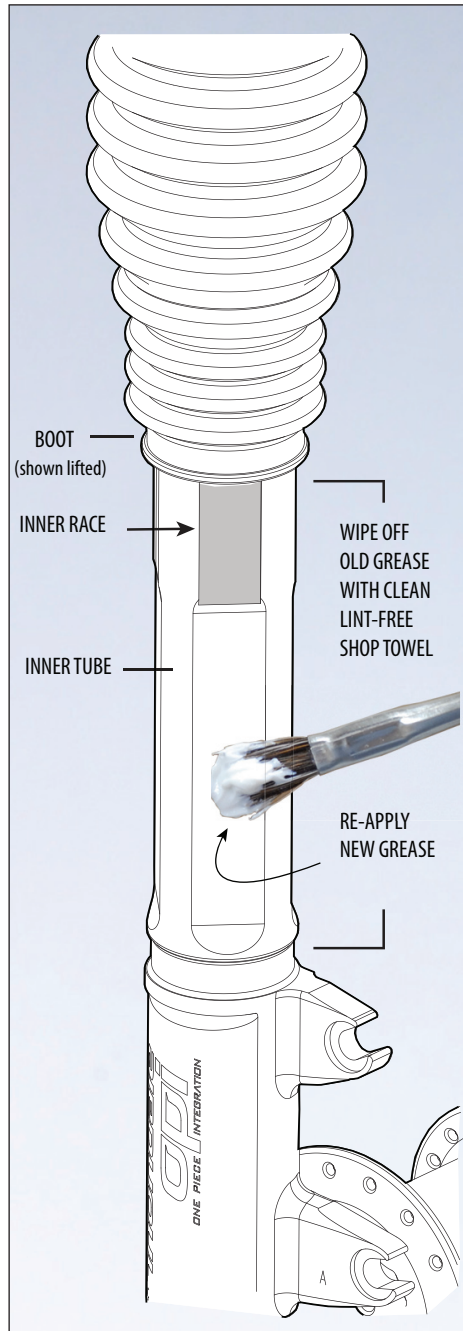

REPLACEMENT PARTS

Lefty Ultra 120 w/PBR

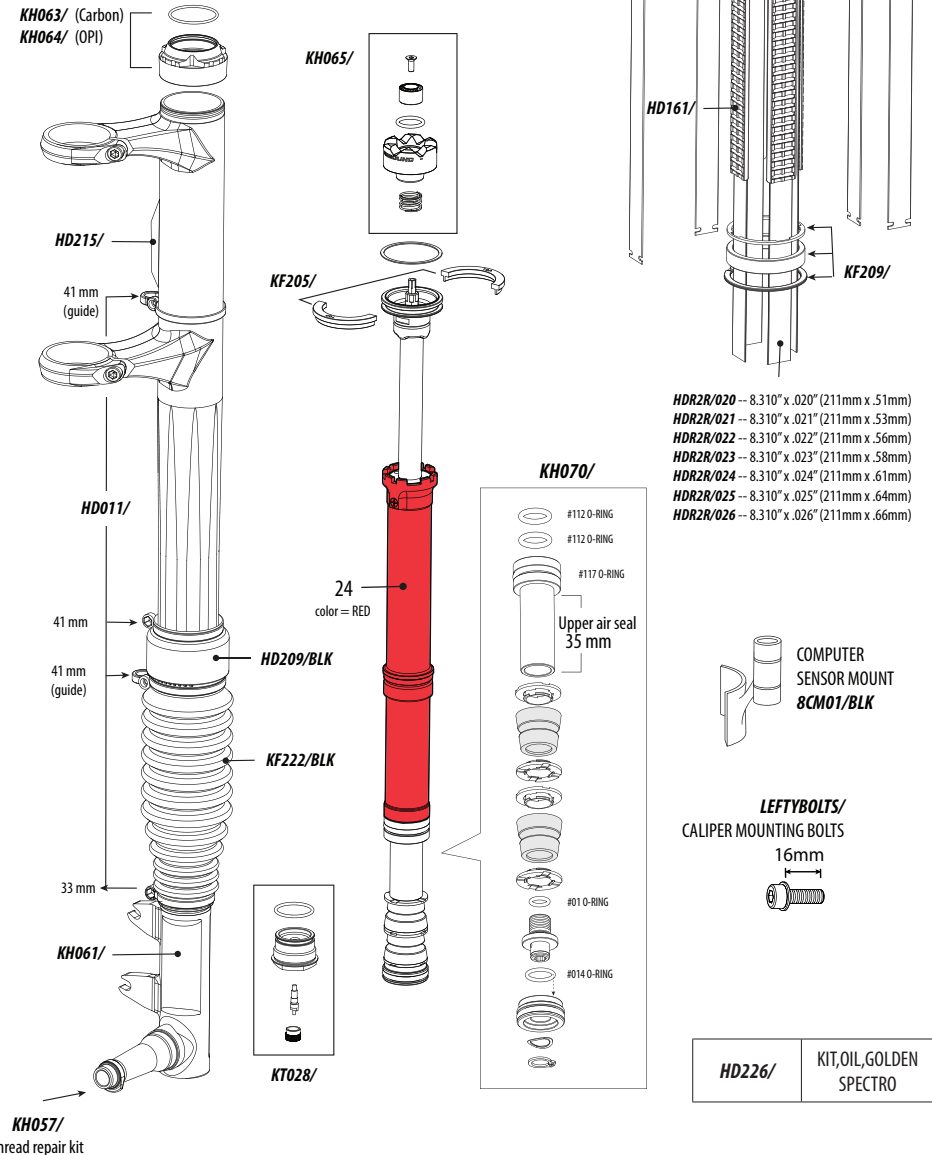

- HDR2R/020 -- 8.310" x .020" (211mm x .51mm)
- HDR2R/021 -- 8.310" x .021" (211mm x .53mm)
- HDR2R/022 -- 8.310" x .022" (211mm x .56mm)
- HDR2R/023 -- 8.310" x .023" (211mm x .58mm)
- HDR2R/024 -- 8.310" x .024" (211mm x .61mm)
- HDR2R/025 -- 8.310" x .025" (211mm x .64mm)
- HDR2R/026 -- 8.310" x .026" (211mm x .66mm)

HD226/ KIT, OIL, GOLDEN SPECTRO

Lefty Ultra 120 w/DLR

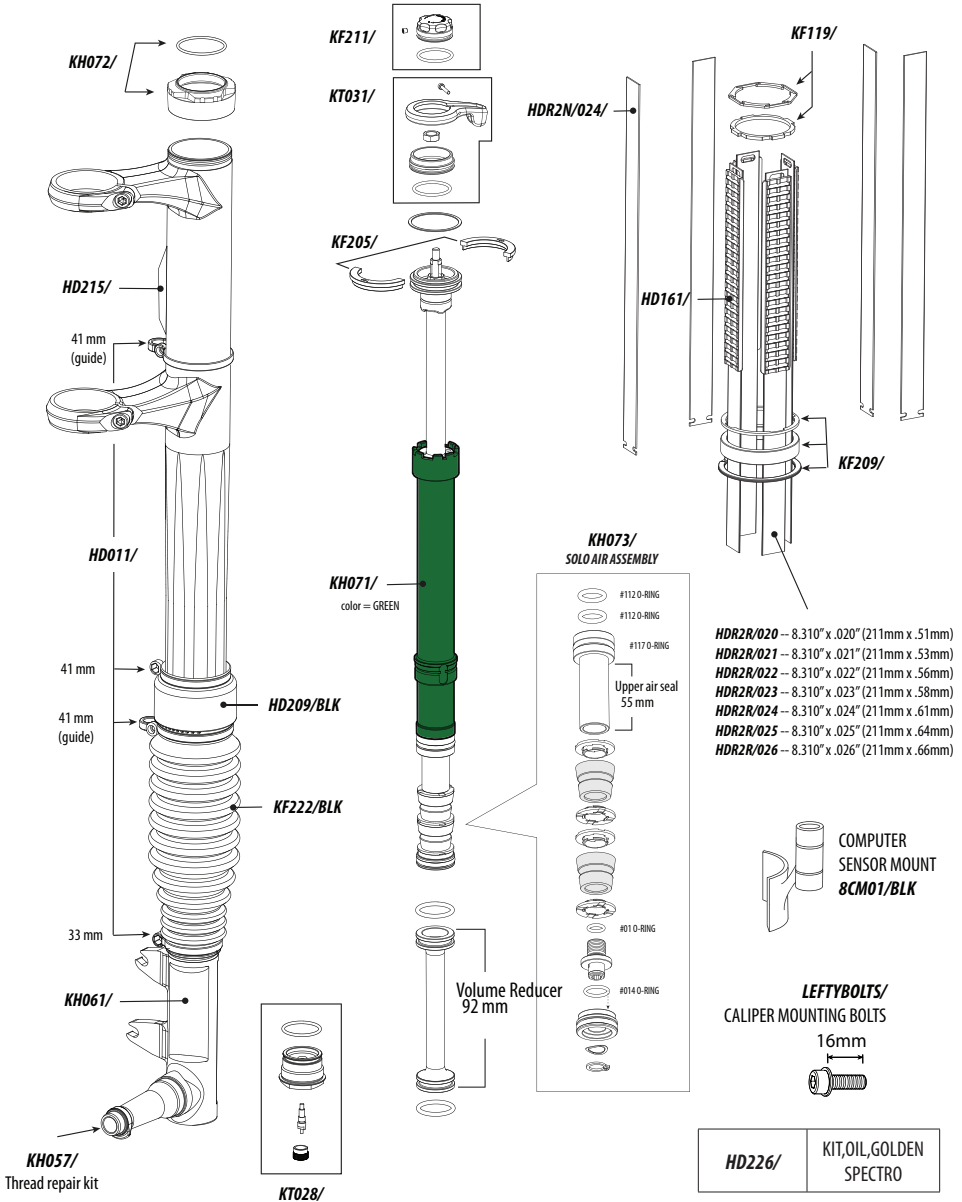

SUPPLEMENT TOWNER'S SMANUALS

CANNONDALE USA

Cannondale Bicycle Corporation
172 Friendship Road, Bedford,
Pennsylvania, 15522-6600, USA
(Voice): 1-800-BIKE-USA
(Fax): 814-623-6173
custserv@cannondale.com
www.cannondale.com

CANNONDALE EUROPE

mail: Postbus 5100
visits: Hanzepoort 27
7570 GC, Oldenzaal, Netherlands
(Voice): + 41 61.4879380
(Fax): 31-5415-14240
servicedeskeurope@cannondale.com

CANNONDALE AUSTRALIA

Unit 6, 4 Prosperity Parade,
Warriewood N.S.W., 2102, Australia
(Voice): (02) 9979 5851
(Fax): (02) 9979 5688
cannondaleaustralia@cannondale.com

CANNONDALE JAPAN

Namba Sumiso Building 9F,
4-19, Minami Horie 1-chome,
Nishi-ku, Osaka 550-0015, Japan
(Voice): 06-6110-9390
(Fax): 06-6110-9361
cjcustserv@cannondale.com