

Lefty Ocho 120

Owner's Manual Supplement

 **WARNING**

**READ THIS SUPPLEMENT AND YOUR
CANNONDALE BICYCLE OWNER'S MANUAL.**

Both contain important safety information. Keep both for future reference.

Safety Messages

In this supplement, particularly important information is presented in the following ways:



WARNING

Indicates a hazardous situation which, if not avoided, may result in death or serious injury.

NOTICE

Indicates special precautions that must be taken to avoid damage.

SYMBOLS:



= Apply NGLI-2 Synthetic grease



= Suspension grease [Buzzy's Slick Honey™](#) or [R.S.P. Slick Kick](#)



= [Loctite® 242](#)



= [Loctite® 262](#)



= [Loctite® 222](#)

= Tightening torque in Newton

N·m meters.

Cannondale Supplements

This manual is a “supplement” to your [Cannondale Bicycle Owner’s Manual](#).

This supplement provides additional and important model specific safety, maintenance, and technical information. It may be one of several important manuals/supplements for your bike; obtain and read all of them.

Please contact your Authorized Cannondale Dealer immediately if you need a manual or supplement, or have a question about your bike. You may also contact us using the appropriate country/region/location information.

You can download Adobe Acrobat PDF versions of any manual/supplement from our website: <http://www.cannondale.com>.

Contacting Cannondale

Cannondale USA

Cycling Sports Group, Inc.
1 Cannondale Way,
Wilton CT, 06897, USA
1-800-726-BIKE (2453)

Cycling Sports Group Europe B.V

CSG Europe (Woudenberg)
Cycling Sports Group Europe B.V.
Geeresteinselaan 57
3931JB Woudenberg
The Netherlands
PH: 00.31.541.200374

International Distributors

Consult our website to identify the appropriate Cannondale Dealer for your region.

CONTENTS

Safety Information	4-7
Identification	8
Technical Information	9-21
Replacement Parts	22-24
Maintenance	25-26
Limited Warranty	27
Notes	28

Your Cannondale Dealer

To make sure your bike is serviced and maintained correctly, and that you protect applicable warranties, please coordinate all service and maintenance through your Authorized Cannondale Dealer.

NOTICE

Unauthorized service, maintenance, or repair parts can result in serious damage and void your warranty.

SAFETY INFORMATION

Intended Use

Ocho Model	Wheel Size Travel Length (mm)	ASTM Condition 3 (Symbol)
Ocho Carbon Ocho Alloy	29" / 120mm	

Condition 3, Cross-Country, XC

INTENDED

For cross-country riding and racing, intermediate terrain (e.g., hilly with small obstacles like roots, rocks, loose surfaces and hard pack and depressions, relatively short suspension travel, supporting nimble handling

NOT INTENDED - DO NOT USE:

No large drops, drop-offs, wooden structures, or dirt embankments requiring long suspension travel or heavy duty components and hard landings.

For Extreme forms of jumping/riding (e.g., hard core mountain, Freeriding, Downhill, North Shore, Dirt Jumping, Hucking).

No Tandems

No Motorcycles

No Engine powered vehicles

⚠ WARNING

Using the Lefty the wrong way is dangerous.

Please read your Cannondale Bicycle Owner's Manual for more information about Intended Use ASTM Conditions 1-5, and riding conditions defined by each.

The intended use and riding conditions defined by on-product markings and owner's manual for the specific Lefty fork model **MUST** match those of the frame.

A mis-match between a Lefty fork and a frame can lead to failure of the frame or Lefty fork. Such a failure can lead to a loss of control, with the risk of serious injury or death to the rider.

If you have any questions consult a Cannondale Dealer or professional bike mechanic with experience in Intended Use conditions in the bicycle industry.

You can be severely injured, paralyzed or killed in an accident if you ignore this warning.

Important Composites Message

WARNING

Your bike (frame and components) is made from composite materials also known as “carbon fiber.”

All riders must understand a fundamental reality of composites. Composite materials constructed of carbon fibers are strong and light, but when crashed or overloaded, carbon fibers do not bend, they break.

For your safety, as you own and use the bike, you must follow proper service, maintenance, and inspection of all the composites (frame, stem, fork, handlebar, seat post, etc.) Ask your Cannondale Dealer for help.

We urge you to read PART II, Section D. “Inspect For Safety” in your Cannondale Bicycle Owner’s Manual BEFORE you ride.

You can be severely injured, paralyzed or killed in an accident if you ignore this warning.

Crash/Impact Damage Inspection

WARNING

After A Crash Or Impact:

Inspect the entire bike, all parts; Look carefully for damage. See “Inspect For Safety” section in the Cannondale Bicycle Owner’s Manual. See Support at www.cannondale.com

Any of the following conditions indicate that serious fork damage is present:

- Any “klunking,” creaking, knocking or unexplained noises.
- A change in travel, and/or function.
- Loss of adjustment features, oil or air leaks, or loose/broken parts.
- Crash or impact damage (cracking, deep scratches, gouges, dents, or bending)
- Carbon which has a soft feel or altered shape, or broken, splintered, or delaminated carbon fiber.)
- Visible cracks, a white or milky color present in carbon fiber section

Continuing to ride a damaged frame / fork increases the chances of frame /fork failure, with the possibility of injury or death of the rider.

Minimum Tire-to-Crown Clearance

WARNING

Modification or installation of damping cartridge/spacers other than specified; or installing over-sized tires can result in incorrect tire-to-crown clearance

Check minimum tire fork/frame clearance with all air released from lefty and fully compressed.

Measure between the top of the properly inflated tire (1) and the bottom of the fork crown (2).

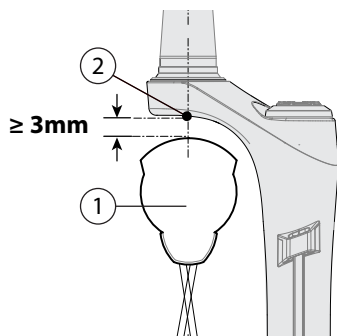

If tire clearance is less than the minimum specified, the rotating tire could come into contact with the fork crown or frame causing the wheel to stop suddenly. This can throw a rider off the bicycle or result in a loss of control and crash.

Compression Assembly

WARNING

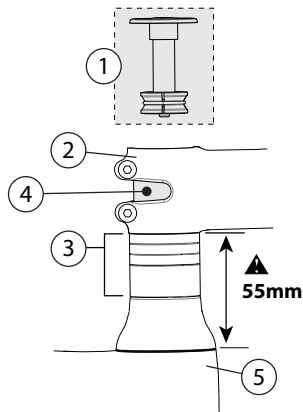

For carbon steerer models, use only the headset compression assembly (1) specified for the model. See "Specifications."

Do not use other headset compression/preload adjusters, shims, and do not modify the steerer.

Do not Stack spacers (3) on top of the stem (2) or exceed the 55 mm Maximum Stack Height (total spacer height stacked between the top of the head tube (5) and the stem (2)). Exceeding maximum stack height with spacers (3) or locating spacers on top of the handlebar stem can place significant stress on the steerer tube (4). It could break.

Follow the Cannondale compression assembly installation instructions.

Use a torque wrench to tighten. Follow stem manufacturer's torque specifications.

Front Brake

The brake mount (1) is compatible with post-mount type brake systems.

WARNING

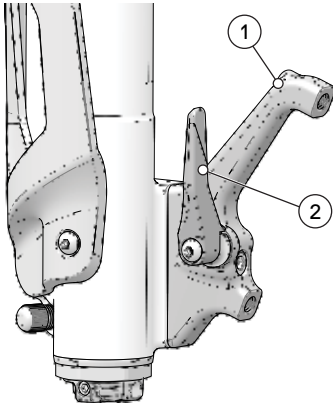

Before riding, make sure the StopLock release lever is in the locked position (shown). See “Front Wheel” removal and installation instructions.

Follow brake manufacturer’s instructions when mounting the brake caliper.

Do not ride without a front brake system attached to the Lefty. A brake system (disc/caliper) is an important secondary wheel retention system. If the brake system is missing or improperly installed, and/or if the wheel hub axle bolt should loosen, the front wheel could slide off the spindle end.

You can be severely injured, paralyzed, or killed in an accident if you ignore this warning.

Making External Adjustments

WARNING

Make any external adjustments only when stopped. Attempting to adjust while riding can result in a loss of control.

You can be severely injured, paralyzed, or killed in an accident if you ignore these warnings.

Disassembly or Modification

WARNING

Modifications can lead to serious fork damage or serious personal injury.

Do not modify the Lefty in any way.

Use only original equipment (OE) replacement parts. See “Replacement Parts.”

Do not attempt damage repair yourself. Have any required repair services or procedures perform by an Authorized Cannondale Dealer or Cannondale Authorized Service Center.

You can be severely injured, paralyzed or killed in an accident if you ignore this warning.

Identification

Parts of the Ocho

1. Steerer
2. Integrated crown race (carbon only)
3. Crown
4. Outer Tube
5. Inner Tube
6. Lockout, Remote
7. Compression, Dial
8. Brake Cable Guide, Upper
9. Brake Guide Tube
10. Wiper Seal
11. O-ring, travel indicator
12. StopLock Brake Mount
13. StopLock Release Lever
14. Wheel Spindle
15. Rebound Adjuster
16. Air Valve
17. Serial Number
18. Wheel Size/Travel
19. Lefty 60 Hub
20. Bolt, axle
21. Label, Warning
22. Serial Number Label
23. Compression Assembly K35009
24. Travel Length (mm)
25. Offset (mm)
26. Wheel Dia. (inches)

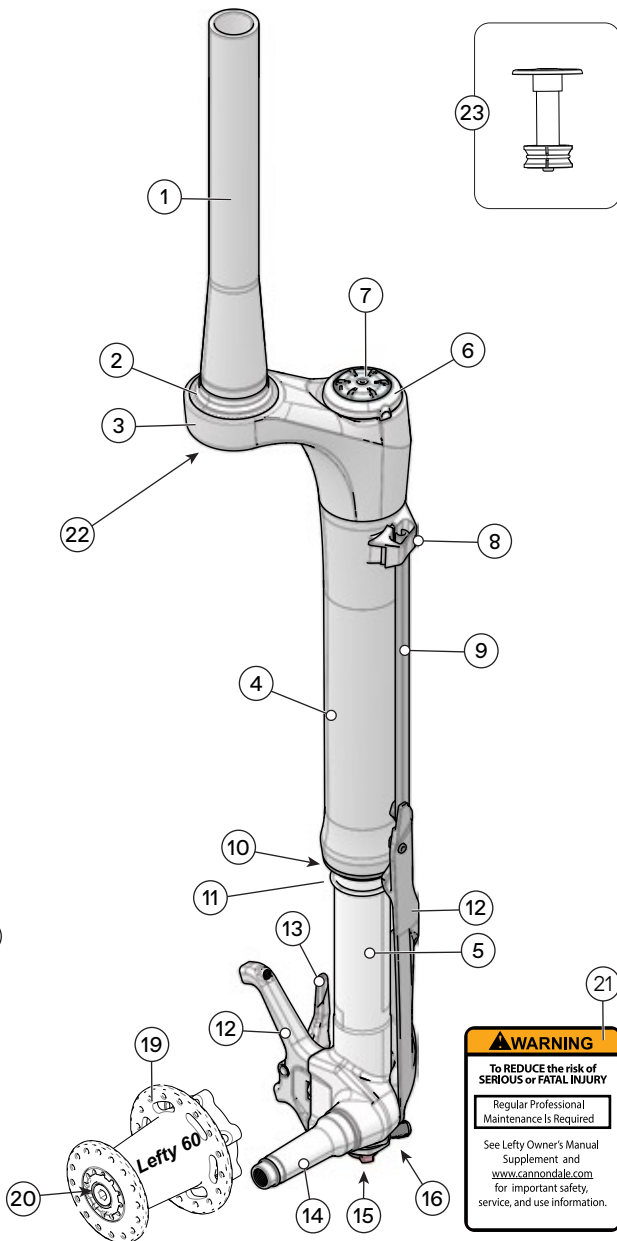
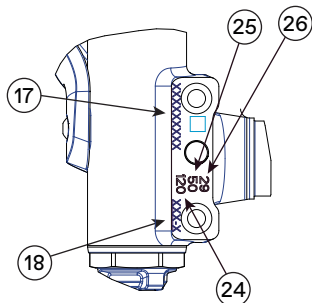

WARNING

To REDUCE the risk of SERIOUS or FATAL INJURY

Regular Professional Maintenance Is Required

See Lefty Owner's Manual Supplement and www.cannondale.com for important safety, service, and use information.

Technical Information

Specifications

	Item	Specification	
		Carbon	
	Travel Length	120mm	110mm
	Wheel Size	29in.	
	External Adjustments	Air Pressure, Rebound, Compression, Lockout	
	Remote Compatibility	"FOX 2 POS (Fox p/n 820-0701250, R) Rockshox OneLoc"	
	Recommended Sag 25%	30mm	27.5mm
	Axle-to-Crown	530mm	520mm
1	Minimum Tire-to-Crown Clearance	3mm	
	Fork Offset	50mm	
	"StopLock Brake Adapter Mount (disc dia./ adapter)	"Minimum: 180mm/ K53131 Maximum: 203mm/ K53131+20mm Post Mount Adapter"	
	Hub Compatibility	Lefty 60	
2	Maximum Tire Size: (Dia./Width)"	760mm x 65mm	
▲	Headset Compression Assy.	"Only Cannondale p/n K35009"	
▲	Maximum Stack Height	55mm	
	Stem Clamp Dia.	28.6mm	
	Steerer: Type/ Taper Length/ Overall Length	Tapered 1.5in - 11/8in/ 86mm/ 330mm	
	Crown Race: Type/Bearing/Degree	Bonded 1.5in. / 36 degree	
	Manual Reset Length +/- 3mm	4mm	
	Air Pressure Limits	"Minimum: 50 psi/2.4 bar Maximum: 250 psi / 17 bar"	
▲	Intended Use	ASTM CONDITION 3: Cross Country, Marathon, Hardtails	
▲	Max. Weight Limit Total (Rider+All Equipment)	305 lbs/ 138kg	

Key:

▲ - Indicates a safety related. Read and follow instructions carefully.

(1) - Measure with all air pressure released and Lefty fully compressed. "See page 6."

(2) - The "maximum width" of a specific tire will change with the tire type/manufacturer/model. A tire width will vary across different point on the tire as well as with the tire ranges of inflation pressure and while riding. This specification is only a guide. Any installed tire, must not be able to contact the Lefty and 3mm of any part of the Lefty maintained.

Product and Specifications are subject to change without notice.

Adjustments

Air Pressure

Set the initial air pressure according to your weight (including the weight of riding gear) based upon the following table. Then, adjust air pressure in small amounts for your riding preference.

Adding more air will result in a stiffer suspension feel. Less air pressure will result in a softer suspension feel. Stay within the minimum and maximum air pressure limits.

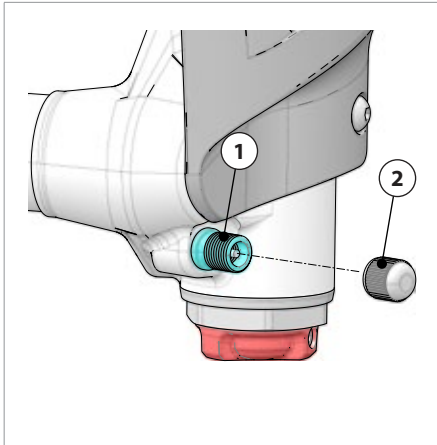

Figure 2

To set air pressure:

1. Clean the area around the valve and the pump end to remove dirt or contaminants.
2. Remove the valve cap (1), attach a high-quality suspension pump to the valve (2).

3. Pressurize to the recommended air pressure
4. When completed, remove the pump; replace the valve cap.

Air Pressure/Rebound Recommendation

RIDER WT.		Air Pressure (psi)	Rebound (Clicks out from slow)
Lbs	Kg		
120	55	68	17
130	59	81	16
140	64	94	15
150	68	107	14
160	73	120	13
170	77	132	11
180	82	145	10
190	86	158	9
200	91	171	8
210	95	184	7
220	100	197	6
230	105	209	5

Air Pressure Limits:

Minimum: 50 psi/ 3.5 bar

Maximum: 200 psi/ 13.75 bar

Air Pressure Limits:

Minimum: 50 psi/ 3.5 bar

Maximum: 200 psi/ 13.75 bar

NOTICE

- Stay within Air pressure limits.
- Attach pump only if valve and pump are clean.

Sag

The rider's position is feet on pedals with weight shift into an "standing attack" position. Sag is directly related air pressure and the distributed weight of the rider on the bike.

The Recommended Sag, found in in the "Specification" section, is a percentage of the full travel. Of course, the Sag % can be adjusted to your riding preference. The GuideGard markings (a) indicates the sag in percent of travel.

To measure sag:

1. Pressurize the Lefty Ocho. See "Air Pressure."
2. Set the Lockout in the Descend mode. See "Lockout."

Compress the Lefty Ocho 30mm, 5-10 times to allow the positive and negative air pressures to equalize.

3. Slide the O-ring (3) against the wiper seal (4).

4. Mount bike in a standing attack position, as shown, next figure.

Have another rider help you hold the bike upright. Avoid bouncing the bike.

Dismount.



5. Measure the SAG as indicated by movement of the O-ring. Corresponding sag percentages are marked on the inside surface of the guard.

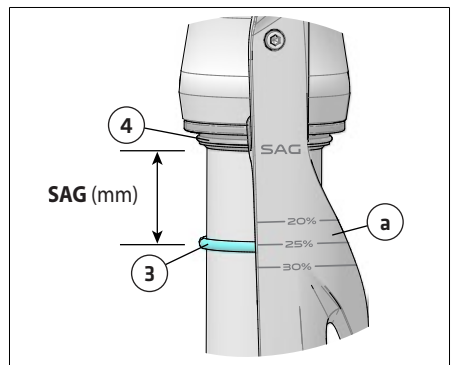

To decrease sag, increase air pressure.

To increase sag, decrease air pressure.

Rebound

The rebound adjustment knob (3) at bottom the of the Lefty controls the speed that Lefty returns after being compressed.

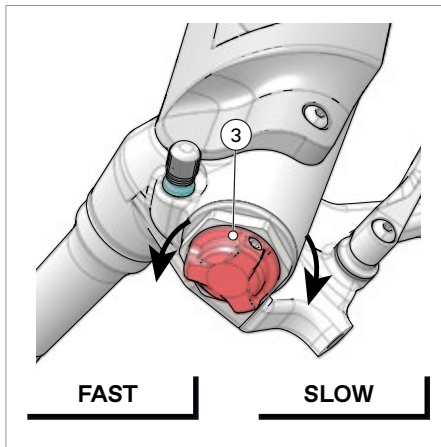

Figure 4

To set rebound:

1. Rotate the adjuster (3) clockwise in the the "SLOW" direction with your fingers until the adjuster stops.
2. From closed, turn the adjuster counter-clockwise toward the "FAST" direction with your fingers and count the "clicks" as you hear or feel them until you reach the desired setting. See Air Pressure/ Rebound table.

To fine tune rebound:

Each click towards the "SLOW" direction decreases rebound speed.

Each click toward the "FAST" direction increases rebound speed

Lockout

MODES:

CLIMB - In climb mode, compression damping is significantly increased making it more difficult to compress the suspension unless large bumps are encountered. Climb mode is a firmer more efficient pedaling platform.

ACTIVE -In active mode, travel suspension is actively absorbing changes in terrain by compressing and extending.

Knob Lever

Use the lockout lever (4) to change between climb and active modes.

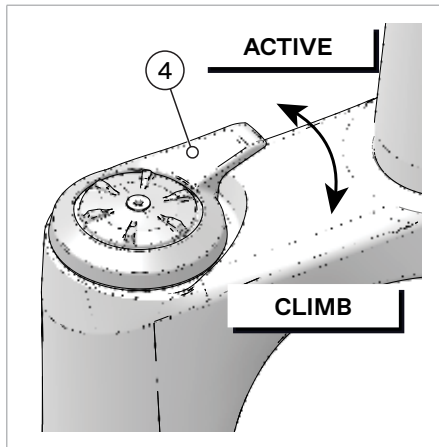
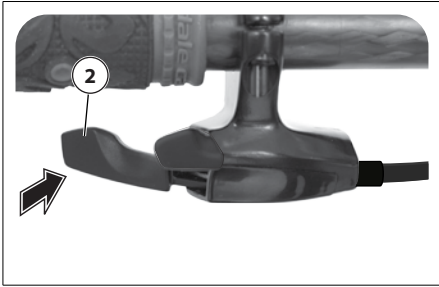

Figure 4

Handlebar Remote Lever

To set to climb mode, press the lockout paddle (2) with your thumb until it latches in place as shown.



To set to active mode, press the lockout release (3) with your thumb. The lockout paddle (2) will return to the position shown.

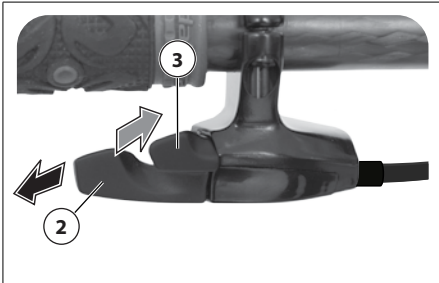

Compression

The compression adjuster (4) is the black knob on the top of the Lefty Ocho crown. The adjuster controls how easily the Lefty Ocho compresses from rider input.

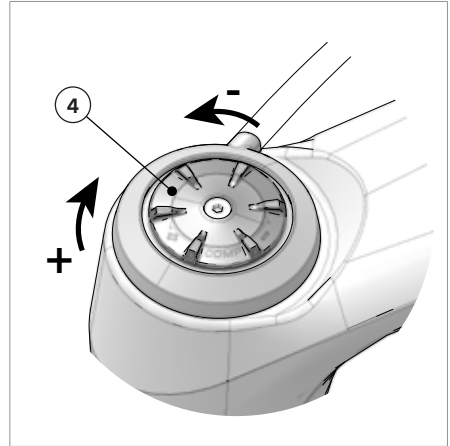

Figure 4

To adjust:

Turn the compression adjuster clockwise, towards the +, to make the Lefty Ocho harder to compress under rider inputs.

Turn the compression adjuster counter-clockwise, towards the -, to make the Lefty Ocho easier to compress under rider inputs.

NOTICE

Do not force the adjuster past the stops.

Forcing the adjuster beyond the stops will damage the damper internals.

Set-Up Steps

Follow these steps in order, to set-up the Lefty

1. Set **Lockout** to **Active** mode.
2. Set the **Air Pressure**.
3. Check **Sag**. Adjust sag as necessary.
5. Set the **Rebound**.
5. Set the **Compression**.

Front Wheel

Removal

1. Secure the bike in a work stand with the front wheel off the ground slightly.
2. Rotate the StopLock release lever (1) 180 degrees so it is pointing downward (un-locked).

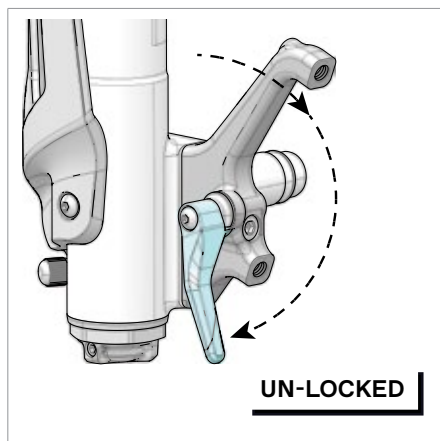

Figure 5

3. Pull the brake mount with attached brake caliper backwards until caliper is clear of the brake rotor.

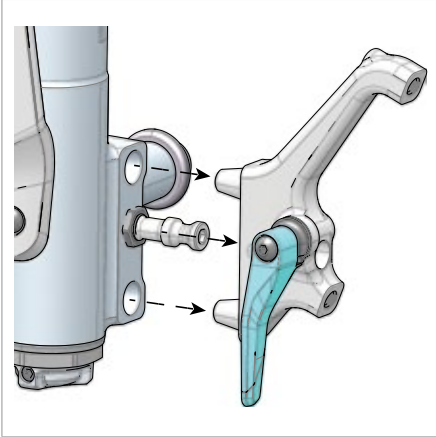

Figure 6
(brake caliper not shown)

NOTICE

- Do not allow the brake to hang by the brake line.
- Support the removed brake mount/ caliper to prevent damage of the brake system while it is detached.



Figure 7

NOTICE

- Make sure the axle bolt is completely disengaged before attempting to remove the wheel.
- Never pull the wheel off forcefully. If the axle bolt is still engaged this will damage the threads.

4. Insert a 5mm hex key into the Lefty hub axle bolt on the drive side of the bike. Turn the axle bolt counter-clockwise. Continue turning until the axle bolt is completely disengaged from the spindle.

5. Slide the wheel off the spindle end.

Important:

While the wheel is off, take steps to prevent damage to the spindle .

Allow the bike to remain in the stand until the wheel is re-installed.

Likewise, while the wheel is removed, be sure to protect the wheel, hub, and brake rotor from damage or contamination. Cover the hub opening to prevent contamination of the inside of the hub.

Installation

1. With bike in a work stand, clean the spindle (1), and axle threads (a). Apply light grease to the threads (a) and outer (b) and inner (c) hub bearing lands.

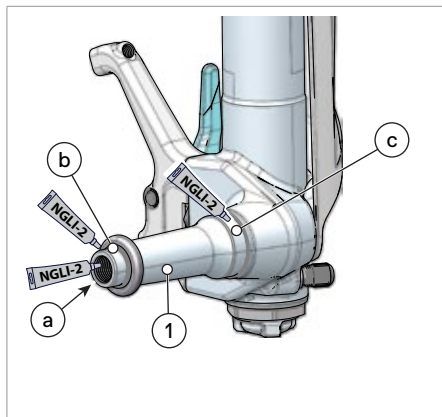

Figure 8

3. Check the inside of the Lefty wheel hub for dirt or contamination, wipe clean if necessary. Apply light grease to the hub bearing inner races.
4. Align and slide the wheel straight on to the spindle. Using a 5 mm hex key by hand, start engagement of the axle bolt to a few threads to confirm correct thread engagement. Once confirmed, tighten the axle bolt to 15 N·m with a torque wrench.
6. With the StopLock release lever turned down, slide the brake mount/caliper into the Lefty. As you do this, make sure the brake rotor locates between the brake pads.
7. With the brake mount firmly seated to the Lefty, turn the StopLock release lever up to lock the brake adapter/caliper onto the lower leg.

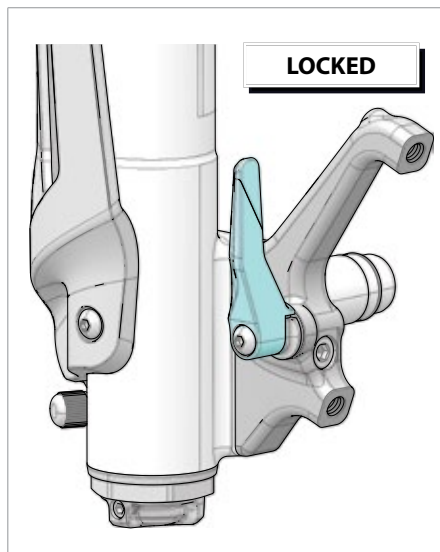

Figure 10

8. Spin the wheel to make sure it rotates freely.
9. Be sure to test the brakes for proper function before riding.



WARNING

Use a torque wrench to tighten.

Prevent grease contamination of brake caliper, pads and brake rotor.

Remote Lockout Setup

1. Cut a length of 4mm derailleur housing (1) to extend between the handlebar lockout remote lever and remote housing (2) stop. Install an inline barrel adjuster 20-30mm from the lever end.
2. Set handlebar lockout remote to Descend mode.
3. Remove compression knob screw (9) and lift off the compression knob (8) to expose the lockout pulley (3).
4. At the lockout lever, feed the shift cable (4) end through to the remote housing. Pull the cable tight to seat the housing in the housing stop.
5. Loosen anchor bolt (5) and feed the cable under the bolt and in the channel as shown.

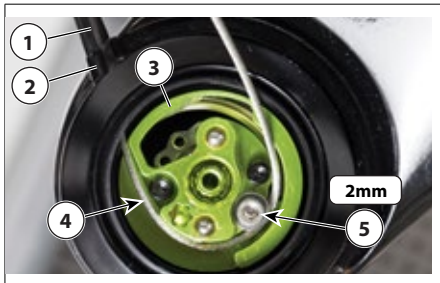

6. Pull the cable tight and tighten the anchor bolt (5) to 0.25Nm.

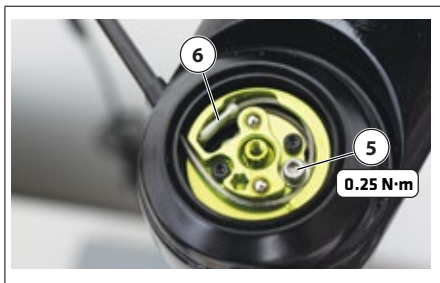

7. Use the barrel adjuster to remove cable slack.
8. Trim the cable 30mm from the cable anchor bolt, install a cable crimp (6) and tuck the cable into the pulley pocket as shown. The cable end must not protrude above the lockout pulley. This will interfere with the compression adjuster knob.
9. Lubricate the adjuster seal (7) with 5W or lighter suspension oil. Do not use grease
10. Insert the compression adjuster knob (8) over the splines (a) on the compression rod. Lightly tighten the compression knob screw (9). Rotate the compression adjuster knob fully clockwise then fully counter clockwise to seat the compression adjuster seal.

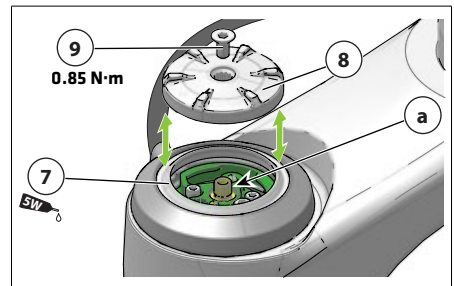

11. Hold the compression adjuster knob stationary with your fingers, tighten the screw (9) to 0.85 Nm.

NOTICE

Over-tightening the screw (9) will result in compression knob being difficult to turn or damage.

GuideGuard

The GuideGuard (6) and protects the Lefty lower leg from damage and the C-tube (3) supports the brake line.

Periodically, check the GuideGuard and C-tube to make sure they are in good condition and attached properly with the mounting screws.

NOTICE

Do not ride, stop riding if parts are missing or damaged.

Replace both the Guide-Guard (6) parts or C-tube (3) with a new ones.

Replacement

1. Place the bike in a workstand and remove the front wheel. See "Wheel Removal."
2. Insert a 4mm hex key through the drive-side of the Lefty spindle until into the head of the fixing bolt (8). Turn counter-clockwise and remove the bolt from the spindle end.
3. Lift the upper rubber clip (1) holding the guide (3) to the clip mount (2) of the Lefty.
4. Remove the small fixing screw (7). Release the brake line from within the guard tube (3) and remove the guard (6) and attached C-tube (3) from the Lefty.
5. See "Replacement Parts."

Fit the new parts to the Lefty in reverse order.

Apply Loctite where indicated and tighten all fasteners to the specified tightening torque.

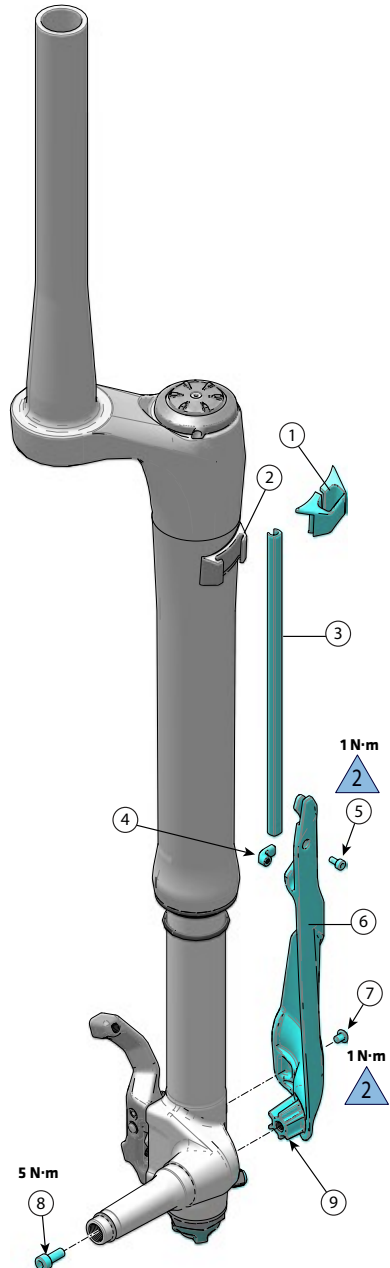

Brake Hose Routing

1. Loosen the 2.5mm hex bolt at the top of the GuideGuard so the hose clamp can move freely. Let the hose clamp hang downwards.



2. Route the brake hose through the channel at the top of the GuideGuard. Rotate the hose clamp so it covers the brake hose. Torque and the hose clamp to 1.5Nm with a 2.5mm hex wrench.

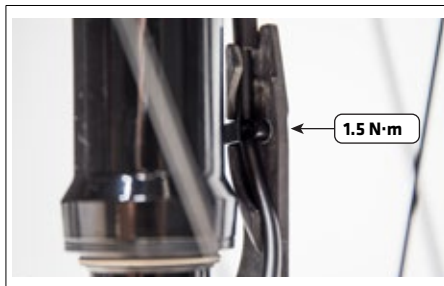

3. Check the brake hose and ensure that it does not contact the Lefty lower leg, brake rotor or wheel spokes.

- a. If the brake hose contacts the Lefty lower leg, remove the StopLock brake mount, rotate the brake caliper 360 degrees clockwise and reinstall the brake mount.

- b. If the brake hose contacts the brake rotor or wheel spokes, adjust the brake banjo angle and/or loosen the hose clamp and draw more brake hose above the GuideGuard.

4. Unclip the upper cable guide from the fork by pushing it upwards.

5. Clip the bottom end of the C-tube over the brake hose. Slide the C-tube downwards until it bottoms out on the GuideGuard then clip onto brake hose.

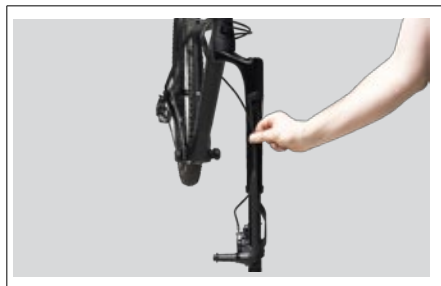

6. Insert the brake hose through the split in the back of the upper cable guide. Insert the upper cable guide into the base and push down to fully seat it.

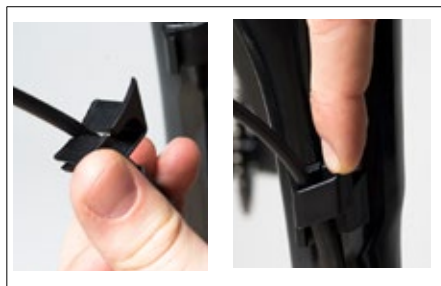

Manual Bearing Reset

Perform the following procedure with the front wheel on the floor.

1. Slide the travel indicator O-ring (1) against the wiper seal (2).
2. Remove the valve cap (3) and attach a suspension pump to the valve (4). Record the air pressure, then release all the air with the pump bleed valve.

NOTE: Due to the small air chamber volume, the suspension pump may read 15-35psi lower than the original fill pressure. Original fill pressure, travel, and ramp ring configuration will influence this effect.

3. Hold the shock pump bleed valve open and fully compress the Lefty by pushing down on the handlebars.
4. Firmly bottom out the Lefty several times.
5. Measure the glossy stanchion tube (5) below the travel indicator o-ring (1). Repeat step 4 until that measurement matches the stanchion length that corresponds to your Lefty in the table below.

Travel	Wheel Size	(A) Reset Length +/- 3 mm
110	29"	4 mm
120	29"	4 mm

6. Set the air pressure recommended for your riding weight or original recorded air pressure.. See "Air Pressure."
7. Remove the shock pump;return the valve cap.

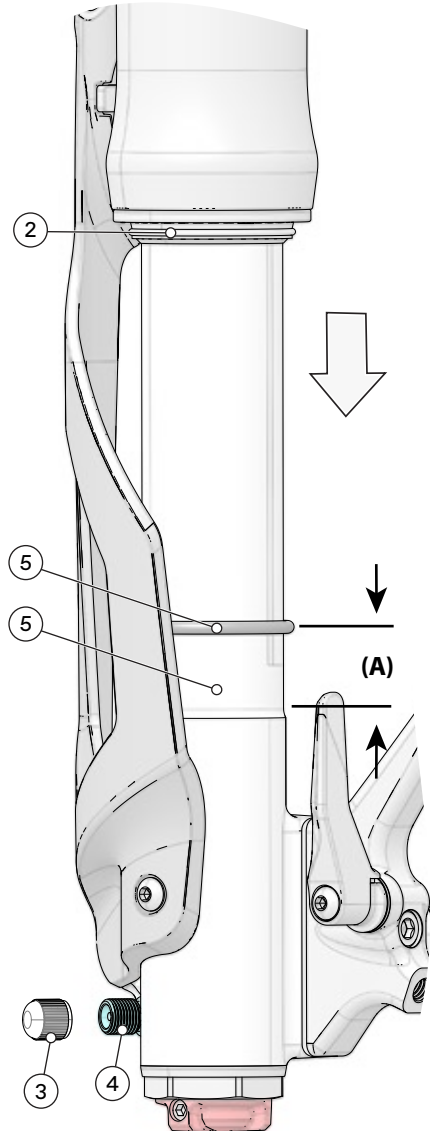

REPLACEMENT PARTS

The following parts are available through an Authorized CSG Dealer:

VIEW	ITEM	CSG PART NUMBER	DESCRIPTION
I	A	K35058	SL Compression Plug w/ Top Cap
I	C	K36111	Lefty Crown Mount Lockout Assembly
I	N	K51041	Lefty Oppo Ramp Clips Qty4
I	H	K51051	Lefty Oppo Upper Air Seal 85mm
I	I	K51071	Lefty Ocho 120 Oppo Air Piston
I	J	K53131	Lefty Ocho 120 StopLock Adapter 180
I	L	K53141	Lefty Ocho 120 Stoplock Hourglass Bolt
--	--	K57021	Lefty Ocho 120 Oppo 100 Hour Seal Kit
I	P2	K53151	Lefty Ocho 120 Guideguard
I	P1	K53161	Lefty Ocho 120 Guideguard 110
I	F	K53089	Lefty Ocho Cable Guide
I	G	K54001	Lefty C Tube Kit 215mm
--	--	K15081	Lefty Decals Ocho 120 Tech Info 2021
I	M1	K5108120	Lefty 120 Air Piston Support RED 120mm
I	O1	K510612020	Lefty Ocho 120 Bottom Cap RED 120mm
I	M2	K510811010	Lefty 120 Air Piston Support BLU 110mm
I	O2	K5106110	Lefty Ocho 120 Bottom Cap BLU 110mm
I	R	K36029	Lefty Rebound Knob Assembly
II	EE	K36039	Lefty Lockout Pulley
II	CC	K36049	Lefty Remote Housing
I	Q	K51039	Lefty SideCar Valve Assembly
I	E	K5203929	Lefty Chamber Damper 100mm 29
I	B	CK9108U000S	39mm 18 Point Lefty Damper Tool
I	S	K91009	Shaft Clamp Tool 10mm and 17.575mm
I	K	K53091	Lefty Ocho Stoplock Release Lever
II	AA	K52049	Lefty Chamber LSC Adjuster Rod
II	BB	K36019	Lefty Compression Knob
"--" Not pictured			

**VIEW
I**

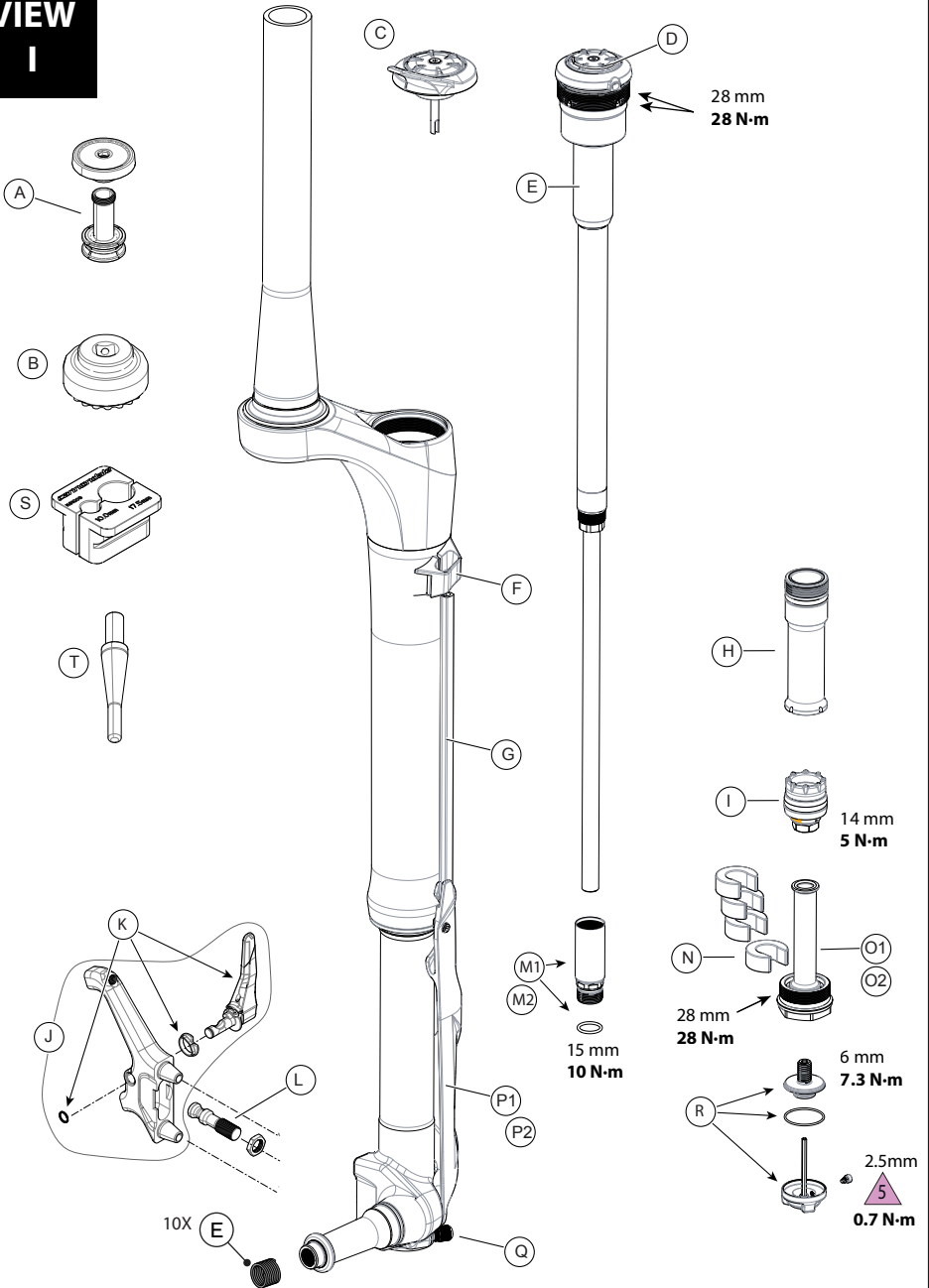

**VIEW
II**

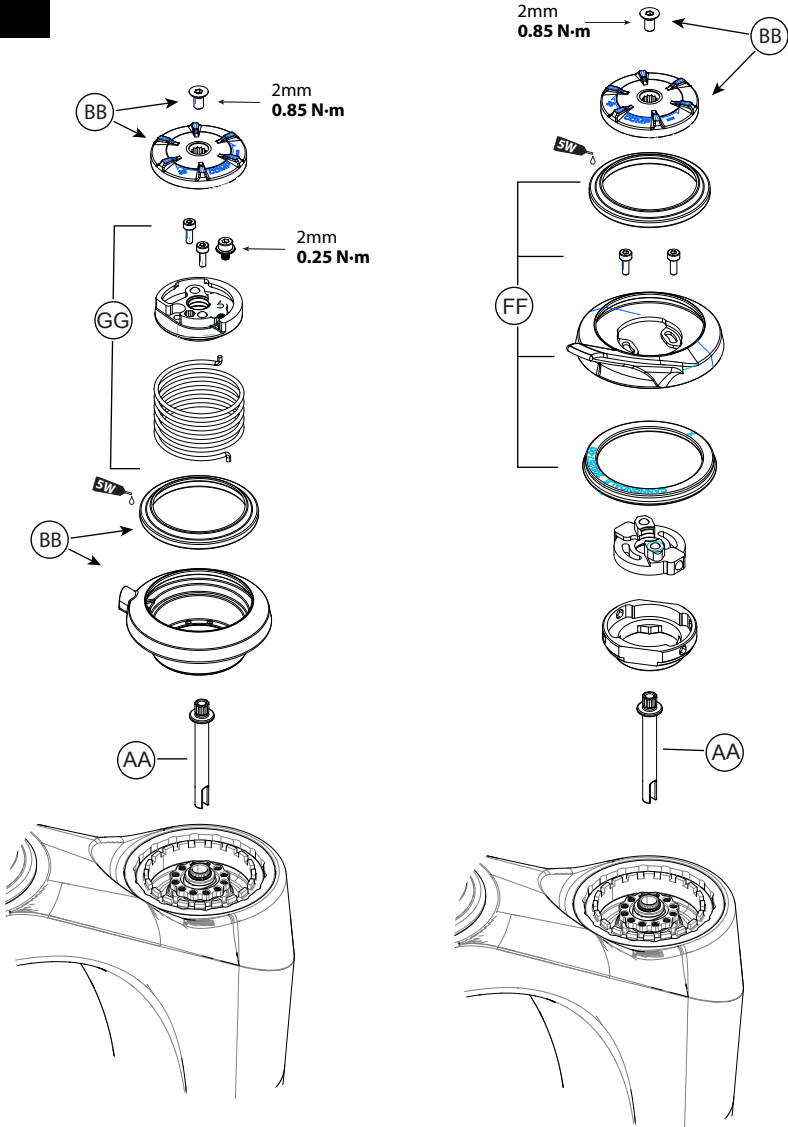

Lockout, Remote

Lockout, Crown Mounted

MAINTENANCE

Schedule

This schedule is intended as a guide only. You must establish a schedule appropriate to your riding style and conditions. All service items indicated as “Owner” are found in this supplement.

Service Item	Frequency/Interval	Performed By
Damage Inspection	Before Every Ride	Owner
Check Fastener Torque	First Ride & Every 4-5 Rides	Owner
Manual Bearing Reset	Every 50 Hours	Owner
100 Hour Service : (Air Spring Service, Damper Inspection)	Every 100 Hours/ Annually	Authorized Cannondale Dealer or Authorized Headshok Service Center
Full Service: (Telescope Rebuild, Air Spring Service, Damper Service)	Every 200 Hours/ Bi-Annually	Authorized Headshok Service Center

Schedule Professional Fork Service Annually (Minimum)

Annually, or when problems are indicated you must have your fork serviced through an Authorized Cannondale Dealer or a Headshok Service Center. Disassembly and inspection by a suspension professional is required to evaluate the internal and external parts, identify wear or damage. Damaged parts must be replaced with new ones and the work must also include any work described in any technical bulletins or product recalls.

Please Note: Shorter service intervals are recommended for riders seeking the highest possible performance or who experience the following situations: (1) High frequency of riding, (2) Adverse conditions while riding, (3) Bicycle storage in an area of high humidity, large temperature changes or outdoor conditions

WARNING

Frequent maintenance and inspection is important to your safety. Ask your Cannondale Dealer to help you develop a complete maintenance program, one that suits where and how you ride. **You can be severely injured, paralyzed or killed riding on a broken or poorly maintained fork.**

Cleaning

Clean using only a mild soap and water solution. Clean water and common liquid dish washing soap will work best. Be sure to cover the adjusters with a clean plastic bag secured with a rubber band or masking tape. Spray off heavy dirt before wiping. Spray indirectly.

NOTICE

Do not use a pressure washer. Don't dry with compressed air. Use a low pressure garden hose and dry with a clean shop towel. Power washing/drying will force contaminants into the fork promoting corrosion, immediately damaging the fork, or resulting in accelerated wear.

Tightening Torques

Correct tightening torque for the fasteners (bolts, screws, nuts) on your bicycle is very important to your safety, the durability and performance of your bicycle. We urge you to have your dealer correctly torque all fasteners using a torque wrench. If you decide to tighten fasteners yourself always use a good torque wrench!

LIMITED WARRANTY

Cannondale Limited Warranty

Cannondale (HEADSHOK, LEFTY, FATTY, SOLO) suspension products are covered under the terms and conditions of the Cannondale Limited Warranty. It is available on the Policies page of our website at: www.cannondale.com Be sure to read the exclusions listed in the limited warranty. For example, damage from accidents and improper maintenance are not covered.

Definitions related to forks:

The fork structure is covered in the FRAMES section of the Cannondale Limited Warranty. "Fork structure" means certain structural parts of the fork, specifically the fork legs, outer tube, the steerer tube, steerer tube clamps and the inner tubes with attached dropouts or spindle. Cable clamps, needle bearings, races, and bushings which are part of the telescopic assembly are normal wear and tear items and ARE NOT covered by the limited lifetime warranty.

The internal fork are covered by the 1 year (2 years in EU countries) warranty against defects in materials or workmanship described in the COMPONENTS section of the Cannondale Limited Warranty. "Internal fork parts" are defined as items such as damping cartridges and their internal parts, seals, o-rings, air cylinders, air pistons, springs, elastomers, bumpers, bushings, needle bearings, races, and oil. Normal wear and tear on these items is NOT covered by this 1 year (2 in EU) warranty. Like brake pads on a car, you should expect to have these items professionally replaced or renewed as you use the fork and they wear.

Fork Warranty Claims

For any warranty claim to be considered, the bicycle/fork must be brought into an Authorized Cannondale Retailer on the continent on which the bicycle/fork was purchased. The bicycle/fork must be in assembled condition and accompanied by the original, dated sales receipt for the bicycle/fork.

Dealer Locator at: www.cannondale.com/Dealerlocator

www.cannondale.com

© 2021 Cycling Sports Group

Lefty Ocho 120 Owner's Manual Supplement

138277 Rev. 1

CANNONDALE USA

Cycling Sports Group, Inc.

1 Cannondale Way,

Wilton CT, 06897, USA

1-800-726-BIKE (2453)

www.cannondale.com

CSG EUROPE

Cycling Sports Group Europe B.V.

Geeresteinselaan 57

3931JB Woudenberg

The Netherlands

service@cyclingsportsgroup.com

CANNONDALE UK

Cycling Sports Group

Vantage Way, The Fulcrum,

Poole, Dorset, BH12 4NU

+44 (0)1202732288

sales@cyclingsportsgroup.co.uk