

# MAINTENANCE

## Schedule

This schedule is intended as a guide only. You must establish a schedule appropriate to your riding style and conditions.

SERVICE ITEM	FREQUENCY (NORMAL RIDING)	WHO?
Check for damage	Pre/Post ride	Bike owner
Check for Tightening Torques	First Ride / Every 4-5 rides	Bike owner
Replace Frame Bumper, Guard	As Needed	Bike owner
Manual Reset	50 hours	Bike owner
Telescope Lubrification	100 hours	Dealer
Damper Service: Air spring/Damping Cartridge Inspection	100 hour or every year	Dealer
Full Service (Telescope Rebuild + Damper service)	200 hours	Headshok Service Center

**RACING** - If you race with your Supermax 2.0, you will have to perform the items listed twice as often. (i.e. 50hrs becomes 25hrs)

### SCHEDULE PROFESSIONAL FORK SERVICE ANNUALLY (Minimum)

Annually, or when problems are indicated you must have your Supermax 2.0 serviced through a Cannondale Dealer or an Authorized Headshok Service Center. Disassembly and inspection by a suspension professional is required to evaluate the internal and external parts, identify wear or damage. Damaged parts must be replaced with new ones and the work must also include any work described in any technical bulletins or product recalls.

### WARNING

**FREQUENT MAINTENANCE AND INSPECTION IS IMPORTANT TO YOUR SAFETY. YOU CAN BE SEVERELY INJURED, PARALYZED OR KILLED RIDING ON A BROKEN OR POORLY MAINTAINED FORK.** Ask your Cannondale Dealer to help you develop a complete maintenance program, one that suits where and how you ride.

## Cleaning

Clean using only a mild soap and water solution. Clean water and common liquid dish washing soap will work best. Be sure to cover the adjusters with a clean plastic bag secured with a rubber band or masking tape. Spray off heavy dirt before wiping. Spray indirectly.

### NOTICE

- DO NOT USE A PRESSURE WASHER. Use a low pressure garden hose. Power washing will force contaminants into the fork promoting corrosion, immediately damaging, or result in accelerated wear.
- DON'T DRY WITH COMPRESSED AIR FOR THE SAME REASON.

## Tightening Torques

Correct tightening torque for the fasteners (bolts, screws, nuts) on your bicycle is very important to your safety, the durability and performance of your bicycle. We urge you to have your Dealer correctly torque all fasteners using a torque wrench. If you decide to tighten fasteners yourself always use a good torque wrench!

Description	Nm	In Lbs	Loctite™
Upper/Lower Clamp Bolts	7-9	62-80	242 (blue)
Guard Screws	1.0	9	242 (blue)
Wheel Axle Bolt	15	133	
Brake Adapter Mounting Bolts	9	80	242 (blue)

## Frame Bumper

The bumper cushions the frame from contact with the Supermax 2.0. Replace it with a new one if it ever becomes damaged, torn, or missing.

**REPLACEMENT:** Clean surfaces well. Remove the backing from the new bumper, position and affix by pressing firmly against the frame.

**IMPORTANT:** Be sure to position the bumper so that when the handlebar is rotated to the left, the bumper prevents fork contact with the the frame. Frame damage can result from using the wrong bumper or positioning a bumper incorrectly. Ask your Cannondale Dealer for help.

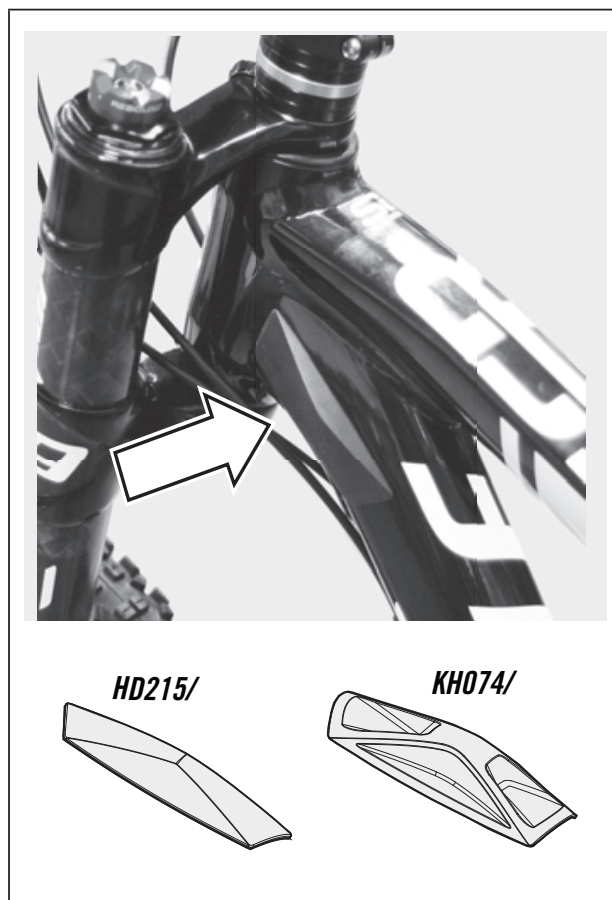

## Moto Guard

The moto guard protects the inner tube surface from damage. It also supports the brake line. Check it periodically. Make sure it is in good condition and attached properly.

### NOTICE

Replace guard with a new one if it becomes damaged. It is a normal wear item.

1. Guard
2. Mounting points
3. Mounting screws

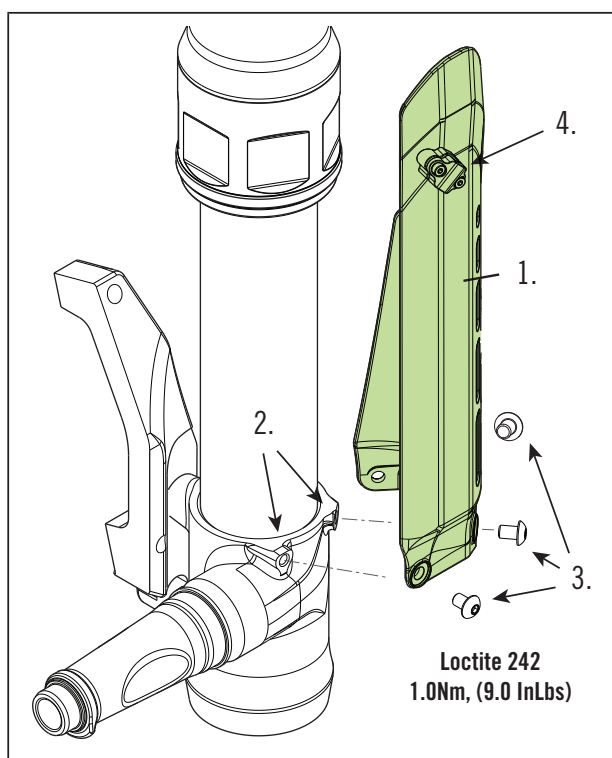

## Brake Line Clamp Position:

To prevent the guard from contact with the brake line clamp during movement, position the clamp according to the table below.

### Minimum Clamp Height

(from the top of the guard to the lower clamp)

SUPERMAX	Travel + 30mm
160/27.5	190mm
140/27.5	170mm
130/29	160mm

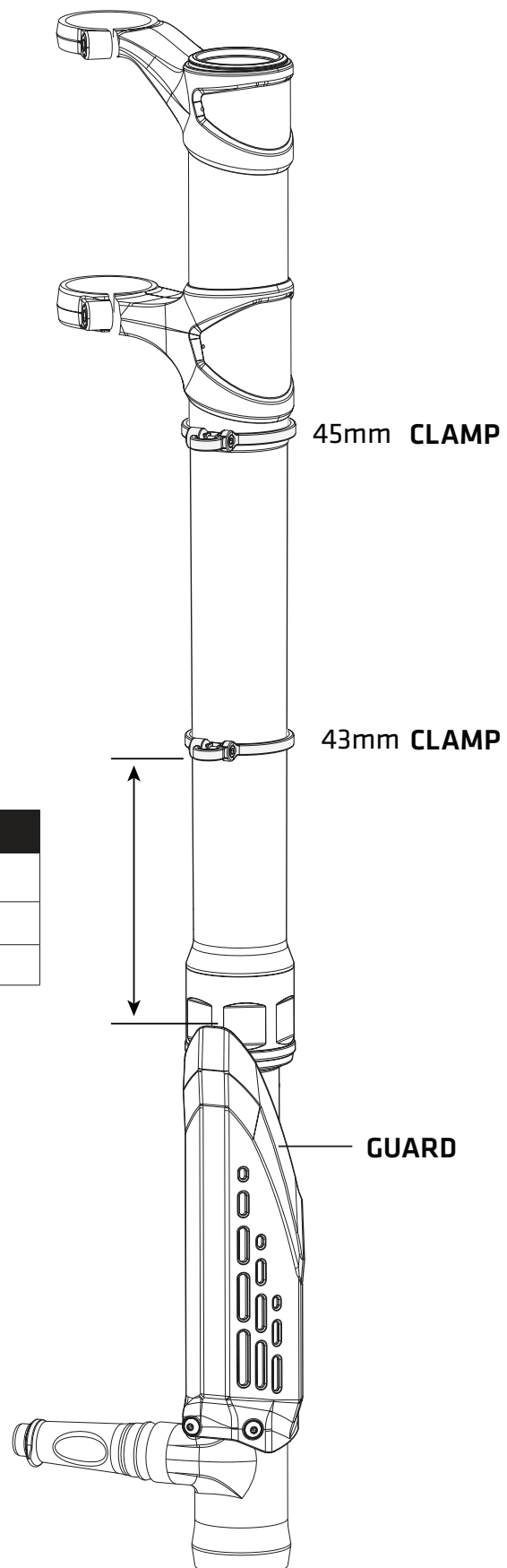

## Manual Reset

### NOTICE:

Do not disassemble or open for the following procedure.

Perform every 50 hours.

1. With your bike on the floor.
2. Cover the brake rotor with a clean shop towel. Remove the Schrader valve cap and hold the valve to release all air pressure. It is normal for a small amount of oil to be expelled with the escaping air.



### WARNING

Contamination can result in reduced or lost braking performance.

3. Hold the valve open while fully compressing the Supermax 2.0 with the the handlebar until it bottoms out. With the air out, using moderate force, bottom out the Supermax 2.0 firmly several times.
4. Now, measure length of exposed inner tube as shown. Repeat step three until the correct measurement for your Supermax 2.0 is reached.
5. When you are finished, reset sag.

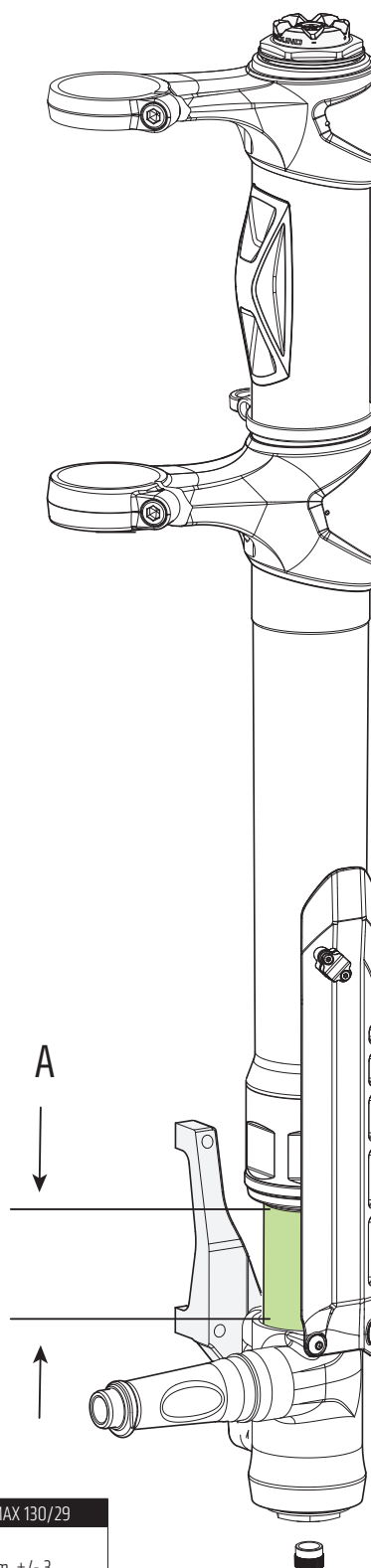

EN

Manual Reset:	SUPERMAX 160/27.5	SUPERMAX 140/27.5	SUPERMAX 130/29
A	20mm +/- 3	20mm +/- 3	35mm +/- 3

**Measure Fully Compressed**