

SUPER FATTY ULTRA DLR, ULTRA DL

Owner's Manual Supplement

GENERAL INFORMATION

Adjusting Air Spring Pressure

Set the air spring pressure using a bicycle suspension pump for your weight according to Recommended Air Spring Pressure Table for your model fork. See page 4. The Schrader valve is located in the fork crown. See Figure 1.

You will need to remove the front wheel to access the crown area.

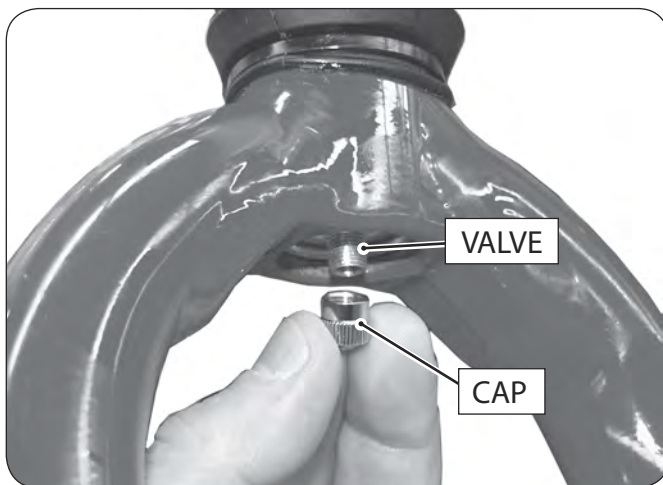

Figure 1

CAUTION

• **BE SURE TO CLEAN** the fork crown area, the **VALVE** end, and the pump end before attaching the pump to the fork. If dirt is pumped into the fork air chamber it can cause rapid damage to the air chamber. • Be sure to replace the **VALVE CAP** when completed. • Stay within pressure limits for your fork.

The wrong air pressure can result in damage or poor fork performance.

Pre-Ride Checklist

Before every ride do the following:

1. Check the fork boot for damage cracking, splits, or tears. Be sure to check in the folds of the boot. Check for any cables or lines rubbing the boot.
2. Check the attachment of the boot at the top and bottom. The upper and lower boot lips should be fitted over the lower collar and fork lip. **NO PART OF THE FORK INNER TUBE (lower leg) SHOULD BE EXPOSED.**
3. Replace the zip ties and cable guides (clamps) as required. Always tighten securely. Replacement boots, zip ties, and cable clamps are available through a Cannondale Dealer.

If you find boot damage, the area under the fork should be inspected for damage. And the damaged boot must be replaced with a new one. Do not try to fix it.

4. Make sure the fork and its adjustment features are operating normally.

WARNING

NEVER RIDE YOUR FORK WITHOUT A BOOT OR WITH A BOOT THAT IS DAMAGED (E.G., CUTS, HOLES, TEARS, ETC.)

CANNONDALE USA (CUSA)

Cannondale Bicycle Corporation
172 Friendship Road
Bedford, Pennsylvania 15522
(Voice): 1-800-BIKEUSA
(Fax): 814-623-6173
custserv@cannondale.com
URL: <http://www.cannondale.com>

CANNONDALE AUSTRALIA (CA)

Unit 6, 4 Prosperity Parade
Warriewood N.S.W 2102
Australia
Phone (02)9979 5851
Fax(02)9979 5688
cannondaleaustralia@cannondale.com

CANNONDALE JAPAN (CJ)

12-5 Harayamadai
5-cho Sakai City
Osaka, Japan 590-0132
(Voice): 011.81.722.99.9399
(Fax): 0722-93-6166
cjcustserv@cannondale.com

CANNONDALE EUROPE (CE)

mail: Postbus 5100
visits: Hanzepoort 27
7570 GC Oldenzaal
Netherlands
(Voice): +31 541 573580
(Fax): 31-5415-14240
servicedeskeurope@cannondale.com

Fork Boot

The boot protects the internal parts (inner tube, races, lubricant, needle bearings, and other internal parts) from contamination and damage. It is a barrier to water, dirt, dust, mud, or grit encountered while riding. If the boot is loose or damaged, dirt, water, dust, salt spray or other contaminants will quickly ruin the fork.

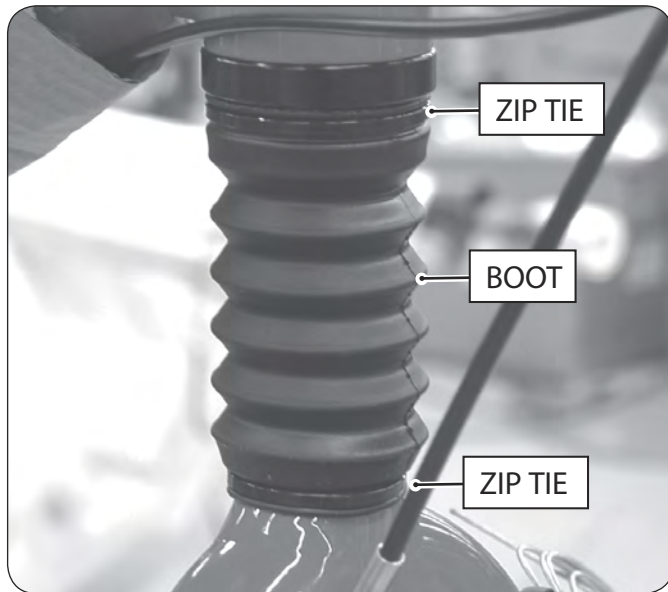

Figure 2

About Grease Renewal Under The Boot

Under the boot, periodic external cleaning and re-greasing helps assure that the inner tube leg surface, bearings races and needle bearings do not suffer damage due to lack of good lubrication. The interval will depend on how the fork is used and in what environments. Average riders should have the service performed every 2 months. Any clean high-quality bicycle bearing grease selected for riding temperatures and environment can be used.

The forks are assembled at our factory using Royal Purple Ultra Performance Grease NLGI #2 (ISO 46 BASE).

1. Place your bike in a work stand with the front wheel off.
2. Carefully cut the upper and lower zip ties securing the fork boot. Some forks may have a screw type band clamp securing the upper portion of the boot. If this is the case, simply loosen the clamp.
3. Lift the unsecured boot up to expose the inner tube (aka inner fork leg).
4. Wipe away any old grease with a clean lint-free shop towel. Cycle the fork and repeat.

CAUTION

Do not use solvents or spray chemicals to clean. Protect the exposed fork from contaminants. Work in a clean area.

5. Thoroughly inspect the inner tube (1) and inner races (2) for any signs of corrosion or damage. Some very light wear to the inner races is normal, however, they are worn-out if any scratches or grooves are evident. If heavy corrosion is present they must be replaced. If ridges can be felt by the tip of a rolling ball point pen over the race, the races should be replaced. If damage is found, the damaged parts must be replaced new before the fork is ridden.

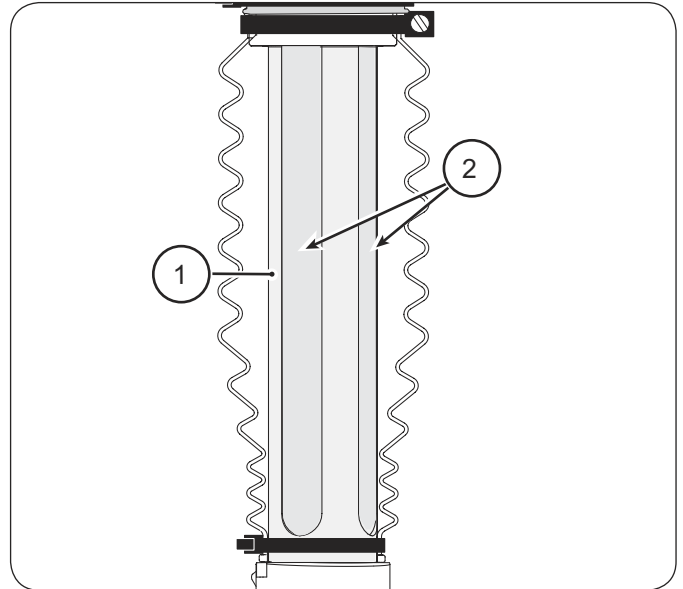

Figure 3

6. Use a stiff nylon brush to rub in a high-quality bicycle grease onto the inner tube and bearing races.

Cycle the fork and re-apply grease. Cycling moves the new grease inside the fork onto the outer tube races and bearing cages. It's OK to leave a good coating under the boot.

Avoid applying grease to the areas just under the boot/zip tie. Wipe it off the inner tube and inner boot to ensure that boot does not slide up when zip tie is re-secured.

7. When you are finished, inspect the condition of the boot. Make sure it is undamaged. Replace it if it is. Re-secure the boot and reassemble the fork.

WARNING

NEVER RIDE YOUR FORK IF THE INNER TUBE, BEARING RACES, OR BEARINGS ARE CORRODED, RUSTED, OR CRACKS ARE PRESENT.

Headshok Headsets

Headshok headset parts are renewable and available through a Cannondale Dealer.

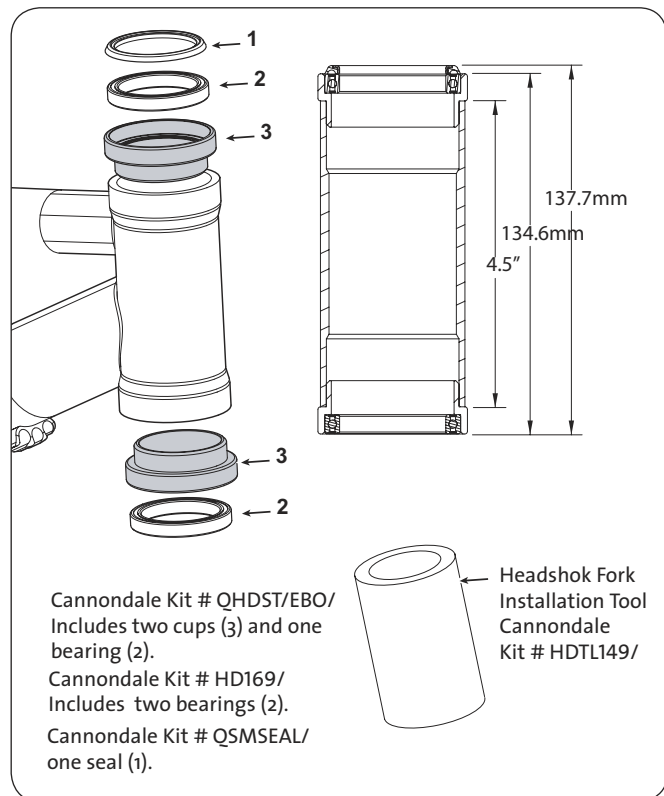

Figure 4

Cleaning

When cleaning your Headshok fork, use only a mild soap and water solution. A clean water and a common dishwashing liquid will work best. Be sure to cover adjustment knobs with a clean plastic bag. Use a rubber band or masking tape to hold the bag in place temporarily. Use an ordinary water hose to gently spray off heavy soils and dirt.

CAUTION

DO NOT powerwash or spray water under high pressure to clean your Headshok fork. Power washing will force contaminants into the fork where they will promote corrosion, immediately damage, or result in accelerated wear.

DO NOT use compressed air to dry your fork. It will have the same damaging effect as power washing.

DO NOT use abrasive or harsh chemical cleaner/solvents which can damage the finish or attack and destroy both the outside and internal fork parts.

Maintenance

Maintenance of your fork is important to your safety and to the useful life of the fork. Frequent inspection by you and regular professional service by your Cannondale Dealer can help ensure years of safe/trouble-free operation.

WHAT TO DO	HOW OFTEN	WHO?
OVERALL FORK INSPECTION Clean and visually inspect entire fork for cracks or damage. Things that can indicate a serious problem: (1) Unusual "klunking" or knocking noises (2) changes in travel (3) Over-extended or compressed boot (4) Changes in the way the fork has been working (5) Loss of adjustments features. (6). Sudden air loss or leaking fluid. If you experience any of the above conditions, have the fork inspected by your Cannondale Dealer before riding it.	Before and After Each Ride	YOU
BOOT INSPECT	Before and After Each Ride	YOU
UNDER BOOT GREASE RENEWAL	Every 2 months	DEALER
BOOT REPLACE (Annual renewal suggested)	As Needed	DEALER
INSPECTION REBUILD Inspect and disassembly of telescope and races, bearings, main telescope parts, damper cartridge, fluids, etc.	RACE: Every 6 months NORMAL: Annually	DEALER

WARNING

YOU CAN BE YOU SERIOUSLY INJURED, PARALYZED OR KILLED RIDING ON A BROKEN OR POORLY MAINTAINED FORK.

Please ask your Cannondale Dealer to help you develop a complete maintenance program. Frequent checks are necessary to identify the problems that can lead to an accident.

Our "Factory Tech Room," provides professional services through Cannondale Dealers for all Headshok suspension forks. Please ask your dealer about the service programs available for your model fork.

SUPER FATTY ULTRA DLR

Recommended Air Spring Pressure

RIDER WT.		PRESSURE	
LBS	KG	PSI	BAR
120	54	50	3.4
130	59	55	3.8
140	63	60	4.1
150	68	65	4.5
160	72	70	4.8
170	77	75	5.2
180	81	80	5.5
190	86	90	6.2
200	90	100	7.2

MINIMUM - 45 PSI, 3.1 BAR
MAXIMUM - 120 PSI, 8.3 BAR

Rebound Knob

The rebound knob is located at the top of the fork. It controls how fast the fork returns following compression. There are a total of 2 ¼ turns of adjustment.

Turn the knob in the "+" direction (clockwise) for more damping and slower rebound speed.

Turn the knob in the "-" direction (counter-clockwise) for less damping and faster rebound speed.

Lockout Lever

The Lockout Lever is located at the top of the fork. It controls the fork lockout. Rotate the lever completely between the stops points to the LOCKED (no travel) or the UNLOCKED (free fork) fork travel.

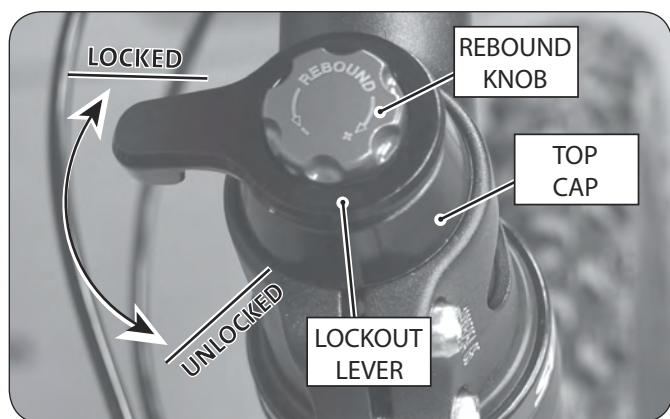

Figure 5

Changing the Lockout Lever Position

The position of the lever handle changed changed to your preference. The change requires the use of a Shimano free wheel tool TL-FW80.

To change the position, loosen the rebound knob set screw and lift off the rebound knob with its O-ring. Remove the Lockout lever retaining nut with a 10mm socket. Insert the TL-FW80 tool into the top cap of the fork and turn it counter-clockwise to loosen the upper cap; do not remove it. Now, refit the lever and turn to locate it to a preferred position. Remove the lever and re-tighten the top cap with TL-FW80 to 16.3 N•m (144 In•Lbs). Reinstall the Lockout lever, nut, rebound knob and set screw.

SUPER FATTY ULTRA DL

Recommended Air Spring Pressure

RIDER WT.		PRESSURE	
LBS	KG	PSI	BAR
120	54	60	4.1
130	59	65	4.5
140	63	70	4.8
150	68	75	5.2
160	72	80	5.5
170	77	85	5.9
180	81	90	6.2
190	86	100	6.9
200	90	110	7.6

MINIMUM - 45 PSI, 3.1 BAR
MAXIMUM - 120 PSI, 8.3 BAR

Lockout Lever

The Lockout Lever is located at the top of the fork. It controls the fork lockout. Rotate the lever completely between the stops points to the LOCKED (no travel) or the UNLOCKED (free fork) fork travel.



Figure 6

Changing the Lockout Lever Position

The position of the lever handle changed changed to your preference. The actual position of the lever handle can be rotated or changed atop the fork for your operating preference. To change the lever, move the lever to a LOCK or UNLOCKED position. Remove the small retaining screw in the center of the lever, lift off the lever, reposition the lever on the large hex nut underneath, then reinstall and tighten the screw. Be sure to tighten it snug.